

CHEROKEE COUNTY SPLOST ROADWAY PROGRAM

PLAN AND PROFILE OF PROPOSED CREEK VIEW SUBDIVISION DRAINAGE IMPROVEMENTS PROJECT 74008

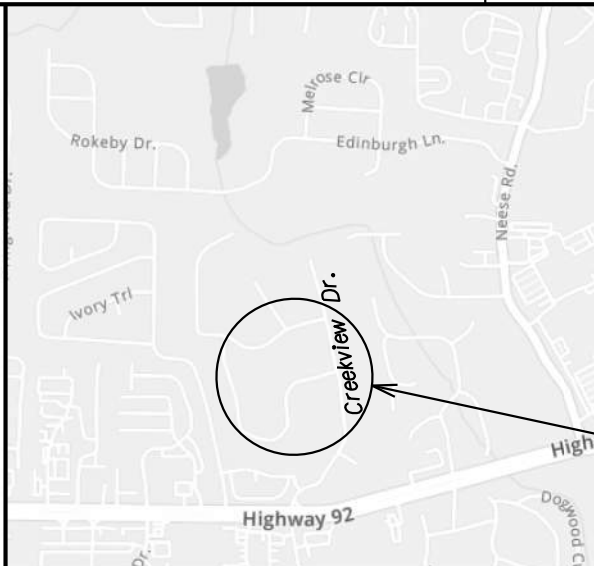
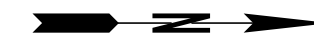

PROJECT
LOCATION

LOCATION SKETCH

THIS PROJECT HAS BEEN PREPARED USING THE HORIZONTAL GEORGIA COORDINATE SYSTEM OF 1984 (NAD 1983)/94 WEST ZONE, AND THE NORTH AMERICAN VERTICAL DATUM (NAVD) OF 1988.

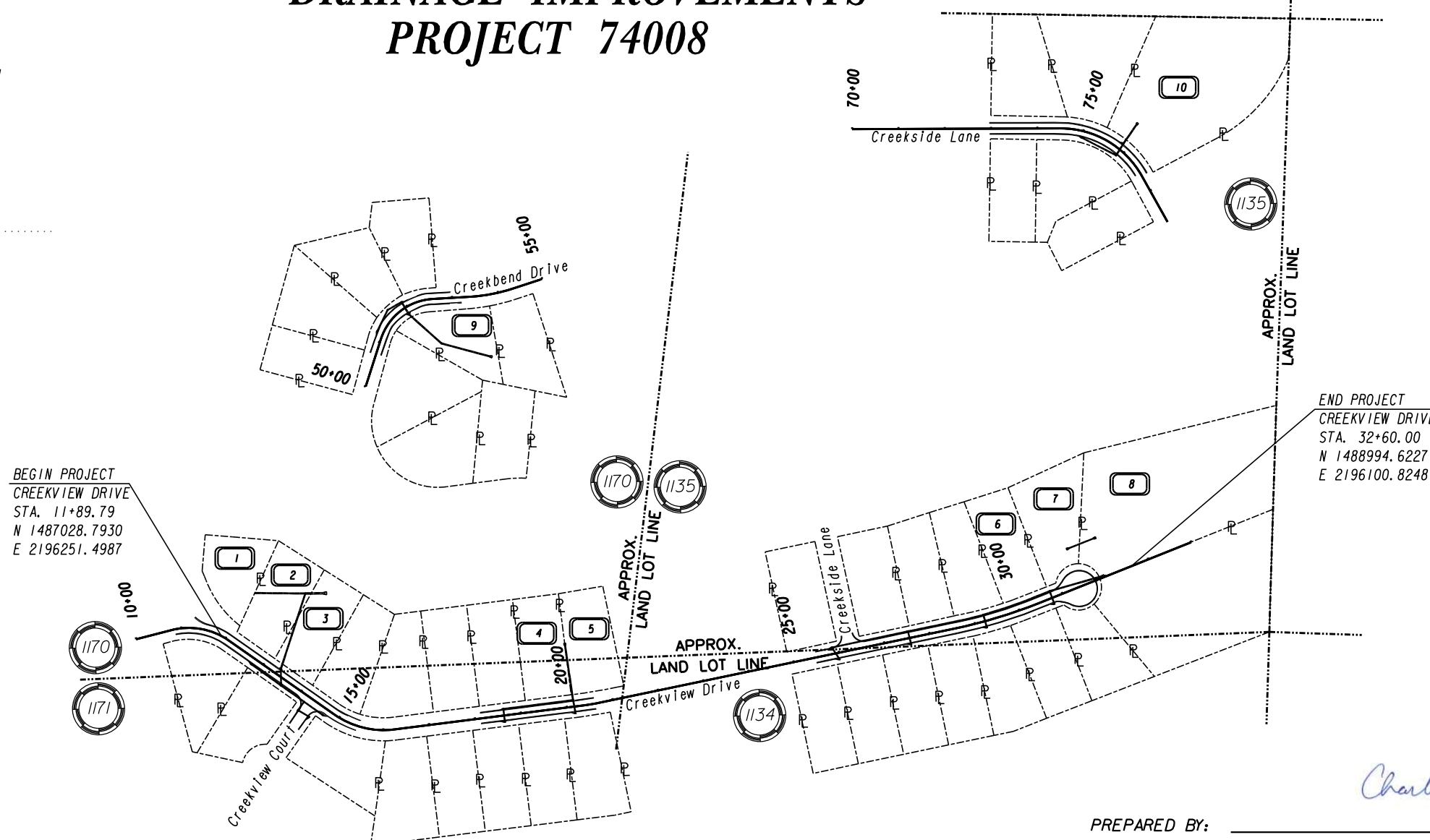

BEGIN PROJECT
CREEKVIEW DRIVE
STA. 11+89.79
N 1487028.7930
E 2196251.4987

END PROJECT
CREEKVIEW DRIVE
STA. 32+60.00
N 1488994.6227
E 2196100.8248

PREPARED BY: *Charlie Lanz*
CHARLIE A. LANZ, PE



PLANS PREPARED BY:
CALCO
ENGINEERING

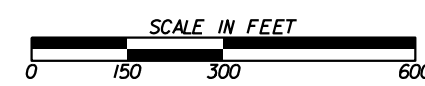

THE DATA, TOGETHER WITH ALL OTHER INFORMATION SHOWN ON THESE PLANS OR IN ANYWAY INDICATED THEREBY, WHETHER BY DRAWINGS OR NOTES, OR IN ANY OTHER MANNER, ARE BASED UPON FIELD INVESTIGATIONS AND ARE BELIEVED TO BE INDICATIVE OF ACTUAL CONDITIONS. HOWEVER, THE SAME ARE SHOWN AS INFORMATION ONLY, ARE NOT GUARANTEED, AND DO NOT BIND CHEROKEE COUNTY IN ANY WAY. THE ATTENTION OF BIDDER IS SPECIFICALLY DIRECTED TO SUBSECTIONS 102.04, 102.05, AND 104.03 OF THE SPECIFICATIONS.

FUNCTIONAL CLASS:
CREEKVIEW DRIVE - LOCAL

THIS PROJECT IS 100% IN CHEROKEE COUNTY AND IS 100% IN CONG. DIST. NO. II.
PROJECT DESIGNATION: EXEMPT

DESIGN DATA	
TRAFFIC ADT. :	CREEKVIEW DR
DIRECTIONAL DIST:	N/A
% TRUCKS:	N/A
SPEED DESIGN:	25 MPH

LENGTH OF PROJECT	LAND LOT
County: Cherokee (057)	1070, 1071, 1134, 1135
NET LENGTH OF ROADWAY	0.392
NET LENGTH OF BRIDGES	0.000
NET LENGTH OF PROJECT	0.392
NET LENGTH OF EXCEPTIONS	0.000
GROSS LENGTH OF PROJECT	0.392

LAND LOT	MILES
1070, 1071, 1134, 1135	0.392

PLANS COMPLETED 01-24-2024	REVISIONS

PROJECT GENERAL NOTES

1. ALL WORK SHALL BE DONE IN ACCORDANCE WITH GEORGIA DEPARTMENT OF TRANSPORTATION STANDARD AND SUPPLEMENTAL SPECIFICATIONS, CURRENT EDITION. ALL NECESSARY LICENSES AND PERMITS SHALL BE OBTAINED BY THE CONTRACTOR AT HIS/HER OWN EXPENSE UNLESS PREVIOUSLY OBTAINED BY THE COUNTY.

2. ALL KNOWN FACILITIES ARE SHOWN SCHEMATICALLY ON PLANS, AND ARE NOT NECESSARILY ACCURATE IN LOCATION AS TO PLAN OR ELEVATION. UTILITY FACILITIES SUCH AS SERVICE LINES OR UNKNOWN FACILITIES NOT SHOWN ON PLANS WILL NOT RELIEVE THE CONTRACTOR OF THEIR RESPONSIBILITY UNDER THIS REQUIREMENT. "EXISTING UTILITY FACILITIES" MEANS ANY UTILITY THAT EXISTS ON THE PROJECT IN ITS ORIGINAL, RELOCATED OR NEWLY INSTALLED POSITION.

3. UTILITY WORK COORDINATION WILL BE REQUIRED AS A PART OF THIS CONTRACT. THE CONTRACTOR SHALL BE REQUIRED TO USE THE ONE-CALL CENTER TELEPHONE NUMBER 811 OR 1-800-282-7411 FOR THE PURPOSE OF COORDINATING THE MARKING OF UNDERGROUND UTILITIES. THE CONTRACTOR'S ATTENTION IS CALLED TO SUB-SECTION 105.06 OF THE GADOT STANDARD SPECIFICATIONS "COOPERATION WITH UTILITIES"

UTILITY CONTACT INFORMATION:

- ATLANTA GAS LIGHT COMPANY - GAS
- AT&T - TELEPHONE
- COMCAST - FIBER
- CHEROKEE COUNTY - WATER & SEWER
- COBB EMC - POWER

4. INGRESS AND EGRESS SHALL BE MAINTAINED AT ALL TIMES TO ADJACENT PROPERTIES. REFER TO SUB-SECTION 107.07 OF THE GEORGIA STANDARD SPECIFICATIONS.

5. IT SHALL BE THE CONTRACTORS RESPONSIBILITY TO FURNISH SUITABLE BORROW MATERIAL FOR THE PROJECT AND TO DISPOSE OF ANY UNSUITABLE OR WASTE MATERIAL IN COMPLIANCE WITH ALL LOCAL, STATE AND FEDERAL REGULATIONS. CONCRETE AND ASPHALT MATERIALS REMOVED FROM THE PROJECT SITE MAY NOT BE PLACED IN FILL LOCATIONS THAT FALL WITHIN EASEMENT AREAS. ALL FILL AREAS MUST BE COMPACTED TO MINIMUM 95% STANDARD PROCTOR.

6. PERFORATED UNDERDRAIN SHALL BE PLACED IN AREAS WHERE WET CONDITIONS EXIST IN THE SUBGRADE AS DIRECTED BY ENGINEER AND PAID FOR IN GRADING COMPLETE.

7. STRUCTURES, TREES, SHRUBS AND OTHER PLANT MATERIAL THAT FALL WITHIN THE RIGHT-OF-WAY AND EASEMENT LIMITS, BUT OUTSIDE THE LIMITS OF CONSTRUCTION, SHALL NOT BE DISTURBED UNLESS DIRECTED BY THE ENGINEER.

8. ALL ROAD SIGNS SHALL BE RESET IF REQUIRED AND PAYMENT SHALL BE INCLUDED IN "TRAFFIC CONTROL".

9. THE CONTRACTOR SHALL BE RESPONSIBLE FOR REMOVING, RELOCATING AND MAINTAINING THE PROPERTY OWNER'S MAILBOX TO AN AREA OUTSIDE CONSTRUCTION LIMITS DURING THE LIFE OF THE CONTRACT. THE LOCATION OF THE BOX SHOULD BE CONVENIENT TO BOTH THE MAIL CARRIER AND THE PATRON. YET NOT INTERFERE WITH PROPOSED WORK. IT MAY BE NECESSARY FOR THE CONTRACTOR TO CONFER WITH THE POST OFFICE SERVING THE AREA. ALL COSTS INCURRED FOR COMPLIANCE WITH THESE REQUIREMENTS SHALL BE INCLUDED IN THE PRICE BID FOR GRADING COMPLETE.

10. LUMP-SUM TRAFFIC CONTROL: THE PRICE BID FOR LUMP-SUM TRAFFIC CONTROL INCLUDE THE COST OF STAGED CONSTRUCTION, MAINTENANCE OF TRAFFIC (INCLUDING AGGREGATE SURFACE COURSE), INSTALLATION AND REMOVAL OF ALL TEMPORARY SIGNAGE, INTERIM PAVEMENT MARKINGS, BARRICADES, AND OTHER INTERIM TRAFFIC CONTROL DEVICES NECESSARY FOR THE CONSTRUCTION AND MAINTENANCE OF THE PROJECT. DEVICES UTILIZED ON THE PROJECT SHALL BE IN COMPLIANCE WITH THE MANUAL ON UNIFORM TRAFFIC CONTROL DEVICES (MUTCD), CURRENT EDITION AND SECTION 150. ALL DEVICES, SIGNS, POSTS, BARRICADES, ETC SHALL BE FROM THE GDOT QUALIFIED PRODUCTS LIST (QPL). ALL DEVICES SHALL BE CRASHWORTHY UNDER AASHTO AND NCHRP 350 REQUIREMENTS. THE ENGINEER MAY DIRECT THAT ADDITIONAL DEVICES AND MARKINGS BE ADDED TO THE TRAFFIC CONTROL PLAN. THE COST OF NOMINAL ITEMS ADDED BY THE ENGINEER SHALL BE INCLUDED IN LUMP-SUM TRAFFIC CONTROL EXCEPT FOR THE ADDITION OF A CHANGEABLE MESSAGE SIGN(S) OR A UNIT PRICE WILL BE DETERMINED WHEN A CHANGEABLE MESSAGE SIGN(S) IS NOT INCLUDED IN THE CONTRACT.

11. ALL CUT AND FILL SLOPES SHALL BE STABILIZED TO COMPLY WITH SECTION 161.3.05.B OF THE SPECIFICATIONS IN ORDER TO REDUCE THE POTENTIAL FOR EROSION. IF THE SEASON DOES NOT PERMIT PERMANENT GRASSING, TEMPORARY STRAW MULCH AND/OR TEMPORARY VEGETATION SHALL BE USED AS PER THE EROSION AND SEDIMENTATION POLLUTION CONTROL PLAN (ESPCP) OR AS DIRECTED BY THE ENGINEER.

12. PAYMENT FOR STORM DRAIN PIPE TO INCLUDE SAWCUTTING, REMOVING AND REPLACING PAVEMENT, CURB & GUTTER, DRIVEWAYS, FLUMES, ETC. PER GDOT STANDARD 1401.

13. EROSION CONTROL MEASURES SHALL BE INSTALLED PRIOR TO ANY LAND DISTURBING ACTIVITIES THAT INVOLVE ENVIRONMENTAL SENSITIVE AREAS (ESA'S) AS DEFINED UNDER SECTION 107.23.F OF THE SPECIFICATIONS. IN GENERAL, EROSION CONTROL ITEMS SHOULD BE INSTALLED PRIOR TO THE START OF ANY LAND DISTURBING ACTIVITIES. THE INSTALLATION OF THE EROSION CONTROL ITEMS MAY BE INSTALLED CONCURRENT WITH THE START OF THE LAND DISTURBING ACTIVITIES.

14. SPRINKLER SYSTEMS TO BE HANDLED AS FOLLOWS:
CASE 1 - SYSTEMS WITHIN THE CONSTRUCTION LIMITS OWNED BY INDIVIDUALS OR PRIVATE COMPANIES ARE TO BE REMOVED TO THE BACK OF THE CONSTRUCTION LIMITS AND PLUGGED
CASE 2 - SYSTEMS SHOWN BY THE PLANS TO BE REMOVED AND RELOCATED SHALL BE RELOCATED TO THE BACK OF THE SIDEWALK. COST SHALL BE INCLUDED IN PRICE BID FOR "GRADING COMPLETE".

15. AN N.O.I (NOTICE OF INTENT) IS NOT REQUIRED FOR THIS PROJECT.

16. ALL EXISTING STORM DRAIN PIPES INCLUDING BOX CULVERTS WITHIN THE CONSTRUCTION LIMITS SHALL BE CLEANED PRIOR TO COMPLETION OF PROJECT. COST TO BE INCLUDED IN GRADING COMPLETE.

17. ALL DRIVEWAYS SHALL BE MAINTAINED DURING CONSTRUCTION. ALL DRIVEWAYS TO BE CONSTRUCTED SHALL BE REPLACED IN KIND I.E. ASPHALT FOR ASPHALT, CONCRETE FOR CONCRETE ETC. ANY OTHER DRIVEWAY MATERIAL OR SPECIALIZED DRIVEWAY WILL NOT BE REPLACED IN KIND (I.E. PAVERS) AND WILL BE REPLACED WITH ASPHALT OR CONCRETE. ALL EARTH OR GRAVEL DRIVES SHALL BE PAVED WITH ASPHALT TO THE RIGHT-OF-WAY LIMIT OR TIE-IN POINT. DRIVEWAYS SHALL BE PAVED AS FOLLOWS:

- ASPHALTIC DRIVES
- RESIDENTIAL- 1-1/2" ASPH. CONC. 12.5 MM SUPERPAVE, 165 LB/SY
- 6" GRADED AGGREGATE BASE
- COMMERCIAL- 1-1/2" ASPH. CONC. 12.5 MM SUPERPAVE, 165 LB/SY
- 2" ASPH CONC. 19 MM SUPERPAVE, 220 LB/SY
- 8" GRADED AGGREGATE BASE

- CONCRETE DRIVES
- RESIDENTIAL- 6" CONCRETE VALLEY GUTTER
- 6" CONCRETE DRIVEWAY
- COMMERCIAL- 8" CONCRETE VALLEY GUTTER
- 8" CONCRETE DRIVEWAY

MAINTENANCE OF TRAFFIC

1. ALL ITEMS NECESSARY FOR COMPLIANCE WITH THESE REQUIREMENTS SHALL BE INCLUDED IN THE PRICE BID FOR "TRAFFIC CONTROL".

2. EXISTING TRAFFIC SIGNS SHALL BE MAINTAINED BY THE CONTRACTOR THROUGHOUT CONSTRUCTION. MAINTENANCE INCLUDES REPLACING DAMAGED AND STOLEN SIGNS, AND PERIODIC CLEANING OF EXISTING SIGNS AND CONSTRUCTION RELATED TRAFFIC CONTROL DEVICES.

3. ALL TRAFFIC CONTROL DEVICES SHALL BE MAINTAINED BY THE CONTRACTOR SO AS NOT TO INTERFERE WITH SIGHT DISTANCES ALONG ANY ADJACENT SIDE ROAD OR DRIVEWAY.

4. CHEROKEE COUNTY RESERVES THE RIGHT TO MODIFY THE MAINTENANCE OF TRAFFIC PLAN AS FIELD CONDITIONS WARRANT. IF ADDITIONAL TRAFFIC CONTROL DEVICES ARE REQUIRED, THESE SHALL BE PROVIDED BY THE CONTRACTOR AT NO ADDITIONAL EXPENSE TO THE COUNTY.

5. THE CONTRACTOR SHALL MAINTAIN INGRESS AND EGRESS TO ALL DRIVEWAYS AT ALL TIMES.



REVISION DATES		GENERAL NOTES	
		CREEK VIEW DRAINAGE IMPROVEMENTS	
CHECKED:	DATE:	DRAWING No.	
BACKCHECKED:	DATE:	04-0001	
CORRECTED:	DATE:		
VERIFIED:	DATE:		

DETAILED ESTIMATE

ITEM NO.	ITEM	UNIT	QUANTITY
ROADWAY ITEMS			
150-1000	TRAFFIC CONTROL -	LS	LUMP
207-0203	FOUND BK FILL MATL, TP II	CY	10
210-0250	UNDERCUT EXCAVATION	CY	10
210-0100	GRADING COMPLETE -	LS	LUMP
550-1180	STORM DRAIN PIPE, 18 IN, H 1-10	LF	1121
550-1240	STORM DRAIN PIPE, 24 IN, H 1-10	LF	1012
550-1360	STORM DRAIN PIPE, 36 IN, H 1-10	LF	38
550-4218	FLARED END SECTION 18 IN, STORM DRAIN	EA	2
550-4224	FLARED END SECTION 24 IN, STORM DRAIN	EA	4
550-4236	FLARED END SECTION 36 IN, STORM DRAIN	EA	1
600-0001	FLOWABLE FILL	CY	5
603-2181	STN DUMPED RIP RAP, TP 3, 18 IN	SY	124
603-7000	PLASTIC FILTER FABRIC	SY	124
668-1100	CATCH BASIN, GP 1	EA	24
668-1110	CATCH BASIN, GP 1, ADDL DEPTH	LF	6
668-4300	STORM SEWER MANHOLE, TP 1	EA	3
668-4311	STORM SEWER MANHOLE, TP 1, ADDL DEPTH, CL 1	LF	3
668-9998	PEDESTAL STYLE INLET	EA	2
163-0240	MULCH	TN	8
163-0541	CONSTRUCT AND REMOVE ROCK FILTER DAMS	EA	5
163-0550	CONSTRUCT AND REMOVE INLET SEDIMENT TRAP	EA	3
163-1930	CONSTRUCT AND REMOVE COMPOST FILTER SOCK, 18 IN	LF	80
165-0041	MAINTENANCE OF CHECK DAMS - ALL TYPES	LF	40
165-0105	MAINTENANCE OF INLET SEDIMENT TRAP	EA	3
165-0110	MAINTENANCE OF ROCK FILTER DAM	EA	5
700-6910	PERMANENT GRASSING	AC	1
700-7000	AGRICULTURAL LIME	TN	2
700-8000	FERTILIZER MIXED GRADE	TN	1
700-8100	FERTILIZER NITROGEN CONTENT	LB	50
700-9300	SOD (TIF TUF BERMUDA)	SY	100



REVISION DATES

DETAILED ESTIMATE
CREEK VIEW
DRAINAGE IMPROVEMENTS

CHECKED:	DATE:	DRAWING No.
BACKCHECKED:	DATE:	09-0001
CORRECTED:	DATE:	
VERIFIED:	DATE:	

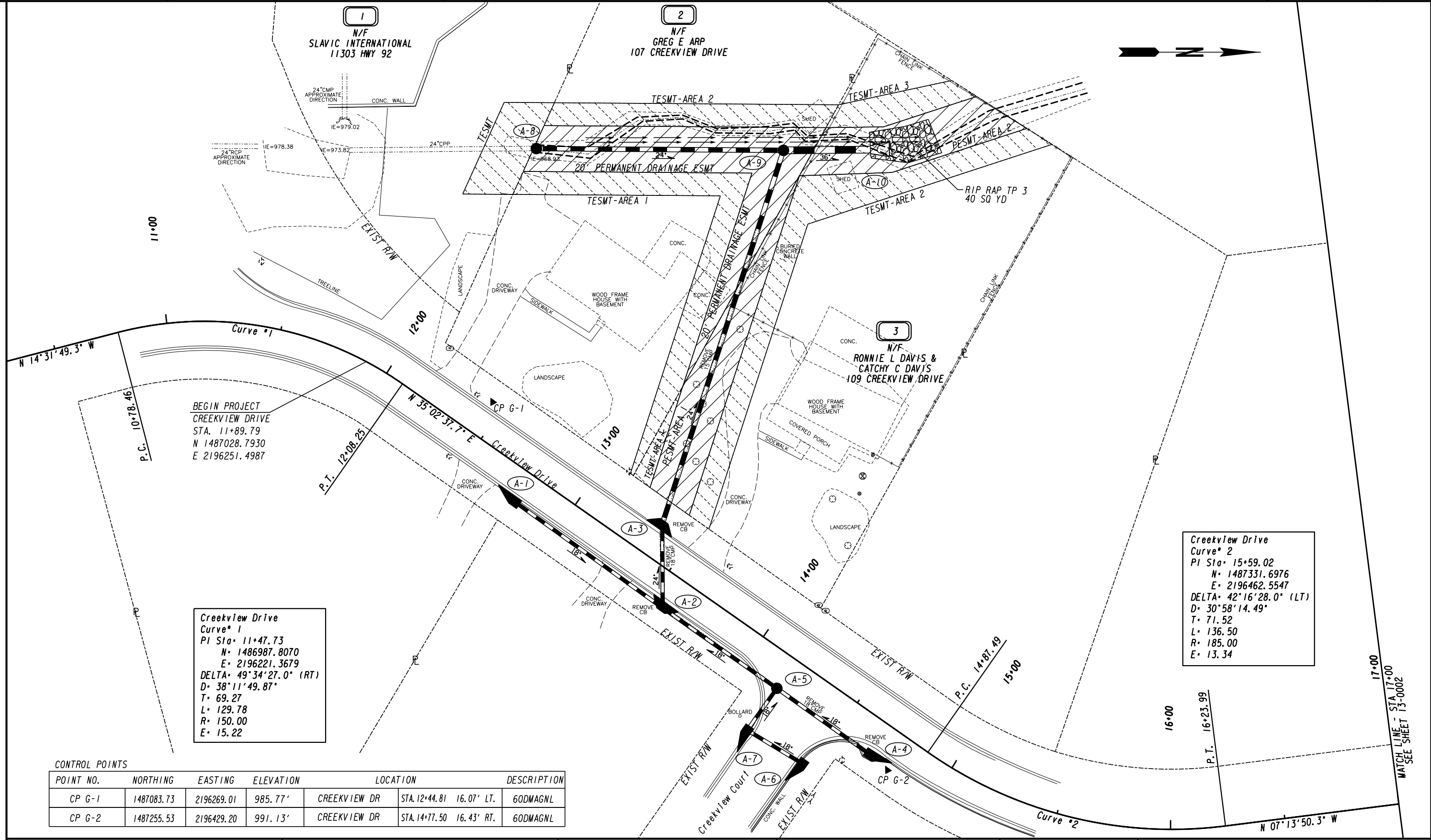

BEGIN PROJECT
CREEKVIEW DRIVE
STA. 11+89.79
N 1487028.7930
E 2196251.4987

**Creekview Drive
Curve # 1**
PI Sta. 11+47.73
N = 1486987.8070
E = 2196221.3679
DELTA = 49°34'27.0" (RT)
D = 38°11'49.87"
T = 69.27
L = 129.78
R = 150.00
E = 15.22

**Creekview Drive
Curve # 2**
PI Sta. 15+59.02
N = 1487331.6976
E = 2196462.5547
DELTA = 42°16'28.0" (LT)
D = 30°58'14.49"
T = 71.52
L = 136.50
R = 185.00
E = 13.34

CONTROL POINTS

POINT NO.	NORTHING	EASTING	ELEVATION	LOCATION	DESCRIPTION
CP G-1	1487083.73	2196269.01	985.77'	CREEKVIEW DR STA. 12+44.81 16.07' LT.	60DMAGNL
CP G-2	1487255.53	2196429.20	991.13'	CREEKVIEW DR STA. 14+77.50 16.43' RT.	60DMAGNL

PROPERTY AND EXISTING R/W LINE
REQUIRED R/W LINE
CONSTRUCTION LIMITS
EASEMENT FOR CONSTR
& MAINTENANCE OF SLOPES
EASEMENT FOR CONSTR OF SLOPES
EASEMENT FOR CONSTR OF DRIVES

-----e-----
BEGIN LIMIT OF ACCESS.....BLA
END LIMIT OF ACCESS.....ELA
---C---F---
REQ'D LIMIT OF ACCESS
REQ'D LIMIT OF ACCESS & R/W
ORANGE BARRIER FENCE
ESA - ENV. SENSITIVE AREA
(SEE ERIT TABLE)

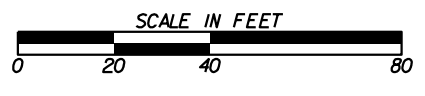

REVISION DATES	

CONSTRUCTION PLAN
CREEK VIEW
DRAINAGE IMPROVEMENTS

CHECKED:	DATE:	DRAWING No.
BACKCHECKED:	DATE:	13-0001
CORRECTED:	DATE:	
VERIFIED:	DATE:	

17+00
WATCH LINE - STA 17+00
SEE SHEET 13-0002

CONTROL POINTS

POINT NO.	NORTHING	EASTING	ELEVATION	LOCATION	DESCRIPTION
CP G-3	1487778.33	2196387.37	971.22'	CREEKVIEW DR STA.20+05.01 18.37' LT.	60DMAGNL

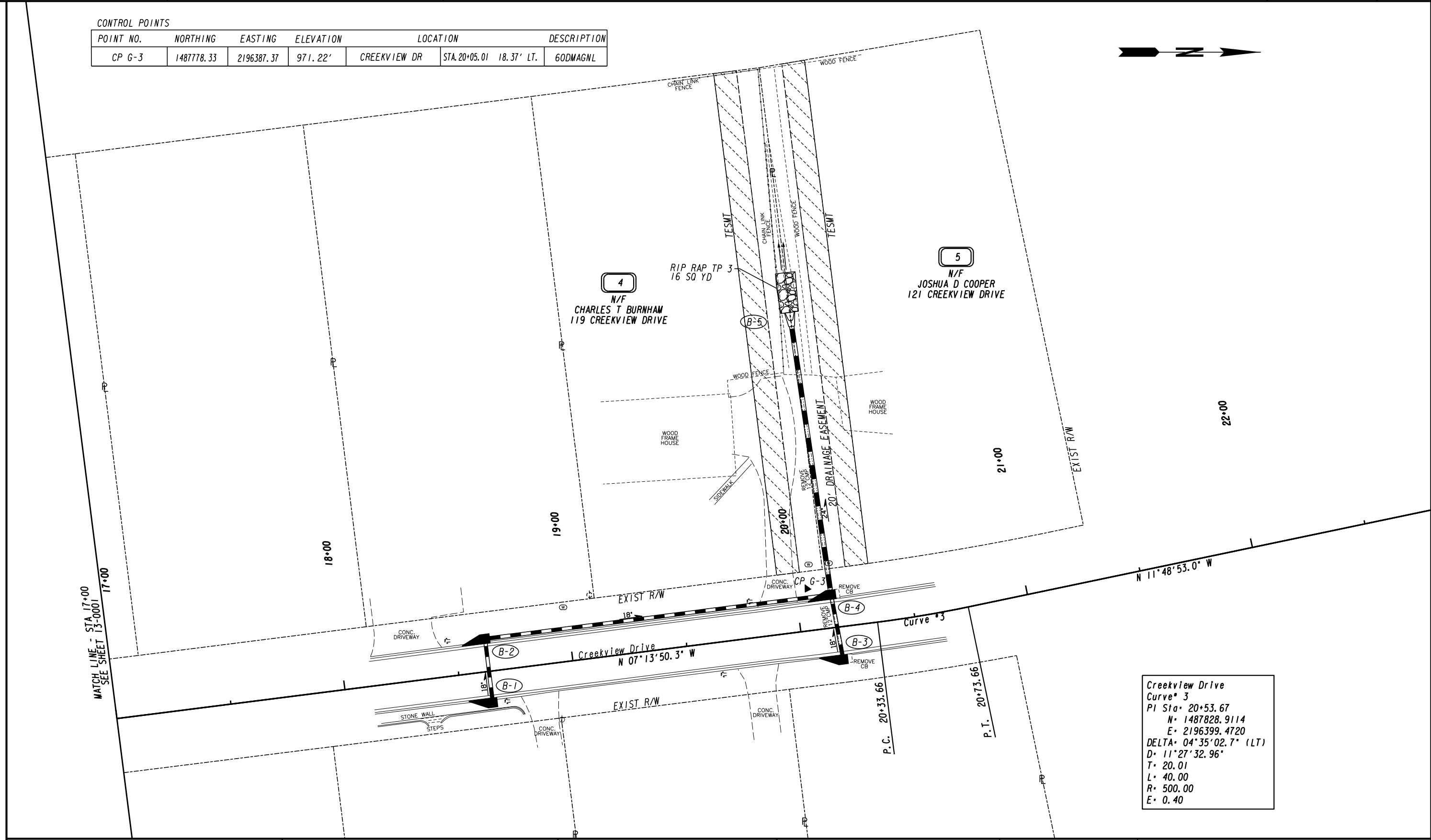

PROPERTY AND EXISTING R/W LINE
 REQUIRED R/W LINE
 CONSTRUCTION LIMITS
 EASEMENT FOR CONSTR
 & MAINTENANCE OF SLOPES
 EASEMENT FOR CONSTR OF SLOPES
 EASEMENT FOR CONSTR OF DRIVES

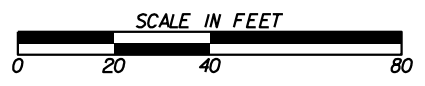
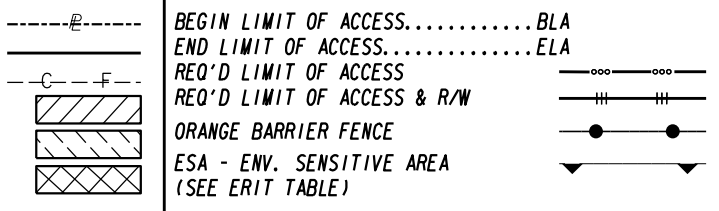

REVISION DATES	

CONSTRUCTION PLAN
 CREEK VIEW
 DRAINAGE IMPROVEMENTS

CHECKED:	DATE:	DRAWING No.
BACKCHECKED:	DATE:	13-0002
CORRECTED:	DATE:	
VERIFIED:	DATE:	

CONTROL POINTS

POINT NO.	NORTHING	EASTING	ELEVATION	LOCATION	DESCRIPTION
CP G-4	1488361.73	2196304.54	956.80'	CREEKVIEW DR STA. 25+94.61 16.17' RT.	60DMAGNL

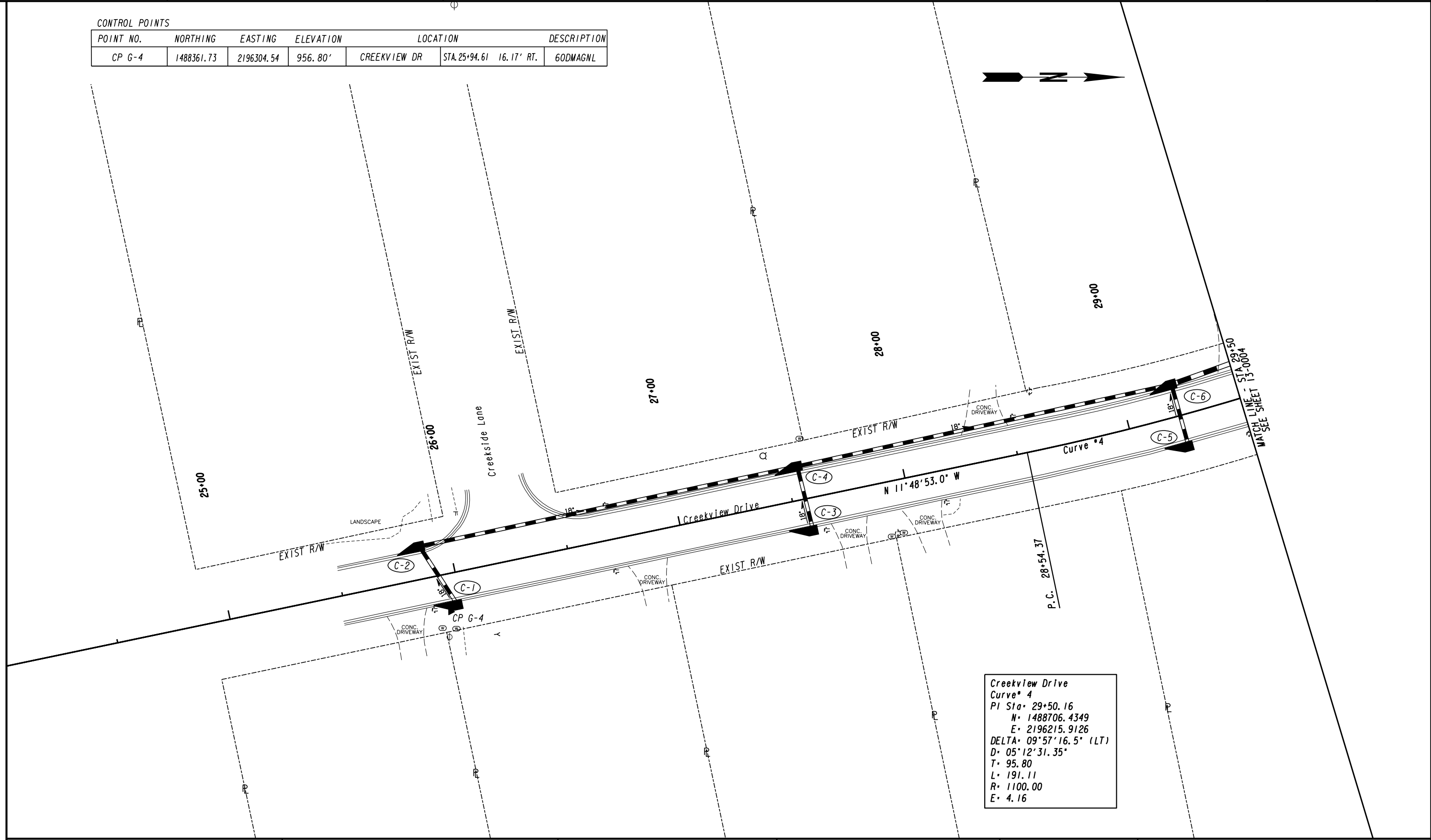

**Creekview Drive
Curve # 4**
 PI Sta: 29+50.16
 N: 1488706.4349
 E: 2196215.9126
 DELTA: 09°57'16.5" (LT)
 D: 05°12'31.35"
 T: 95.80
 L: 191.11
 R: 1100.00
 E: 4.16

PROPERTY AND EXISTING R/W LINE
 REQUIRED R/W LINE
 CONSTRUCTION LIMITS
 EASEMENT FOR CONSTR
 & MAINTENANCE OF SLOPES
 EASEMENT FOR CONSTR OF SLOPES
 EASEMENT FOR CONSTR OF DRIVES

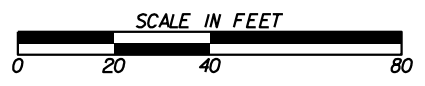
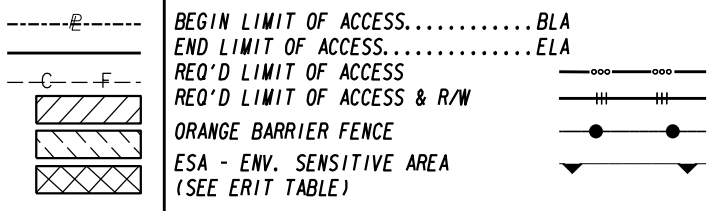

REVISION DATES	

CONSTRUCTION PLAN
CREEK VIEW
DRAINAGE IMPROVEMENTS

CHECKED:	DATE:	DRAWING No.
BACKCHECKED:	DATE:	13-0003
CORRECTED:	DATE:	
VERIFIED:	DATE:	

Creekview Drive
Curve # 4
 PI Sta= 29+50.16
 N= 1488706.4349
 E= 2196215.9126
 DELTA= 09°57'16.5" (LT)
 D= 05°12'31.35"
 T= 95.80
 L= 191.11
 R= 1100.00
 E= 4.16

6
 N/F
 HUGH LEE BENTLEY
 137 CREEKVIEW DRIVE

7
 N/F
 JULIA W CRIDER
 139 CREEKVIEW DRIVE

8
 N/F
 WILLIAM F HYDE &
 MARTHA L HYDE
 141 CREEKVIEW DRIVE

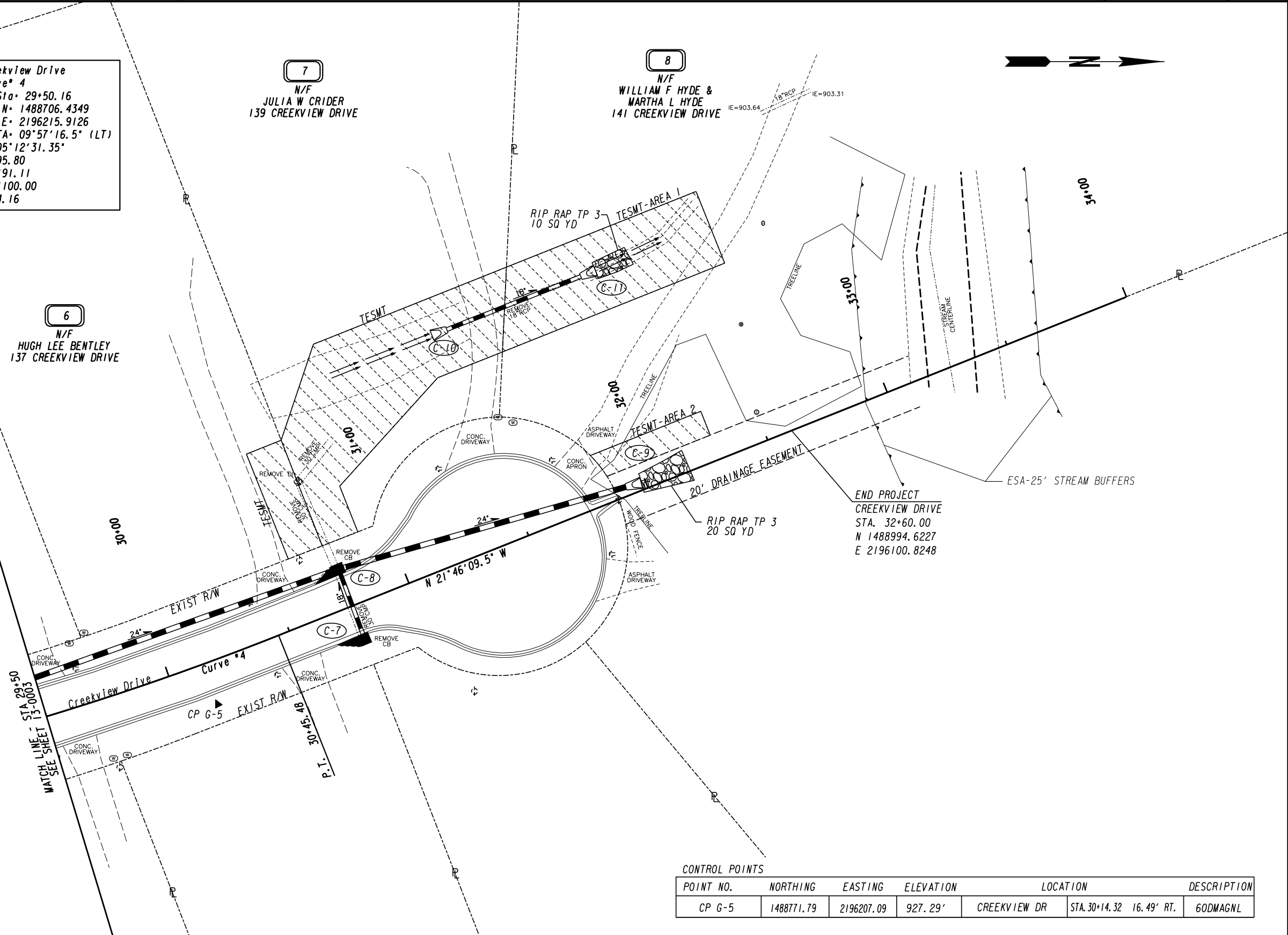

CONTROL POINTS

POINT NO.	NORTHING	EASTING	ELEVATION	LOCATION	DESCRIPTION
CP G-5	1488771.79	2196207.09	927.29'	CREEKVIEW DR STA. 30+14.32 16.49' RT.	GODMAGNL

PROPERTY AND EXISTING R/W LINE
 REQUIRED R/W LINE
 CONSTRUCTION LIMITS
 EASEMENT FOR CONSTR
 & MAINTENANCE OF SLOPES
 EASEMENT FOR CONSTR OF SLOPES
 EASEMENT FOR CONSTR OF DRIVES

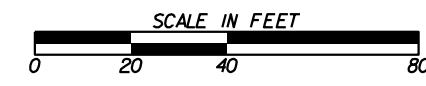
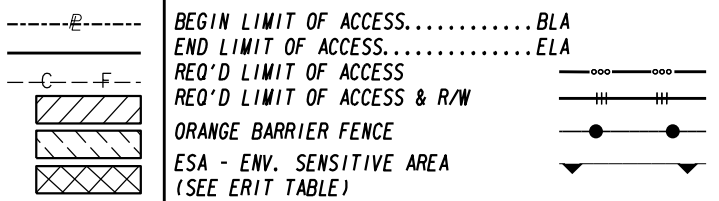

REVISION DATES

NO.	DATE	DESCRIPTION

CONSTRUCTION PLAN
 CREEK VIEW
 DRAINAGE IMPROVEMENTS

CHECKED:	DATE:	DRAWING No.
BACKCHECKED:	DATE:	13-0004
CORRECTED:	DATE:	
VERIFIED:	DATE:	

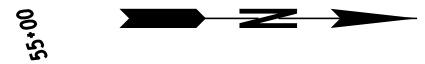

Creekbend Drive
 Curve* 5
 PI Sta: 51+93.11
 N= 1487399.8483
 E= 2195528.0624
 DELTA= 68°40'19.5" (RT)
 D= 45°50'11.84"
 T= 85.38
 L= 149.82
 R= 125.00
 E= 26.38

Creekbend Drive
 Curve* 6
 PI Sta: 53+87.46
 N= 1487614.7466
 E= 2195514.9014
 DELTA= 14°43'54.8" (LT)
 D= 16°22'12.80"
 T= 45.25
 L= 89.99
 R= 350.00
 E= 2.91

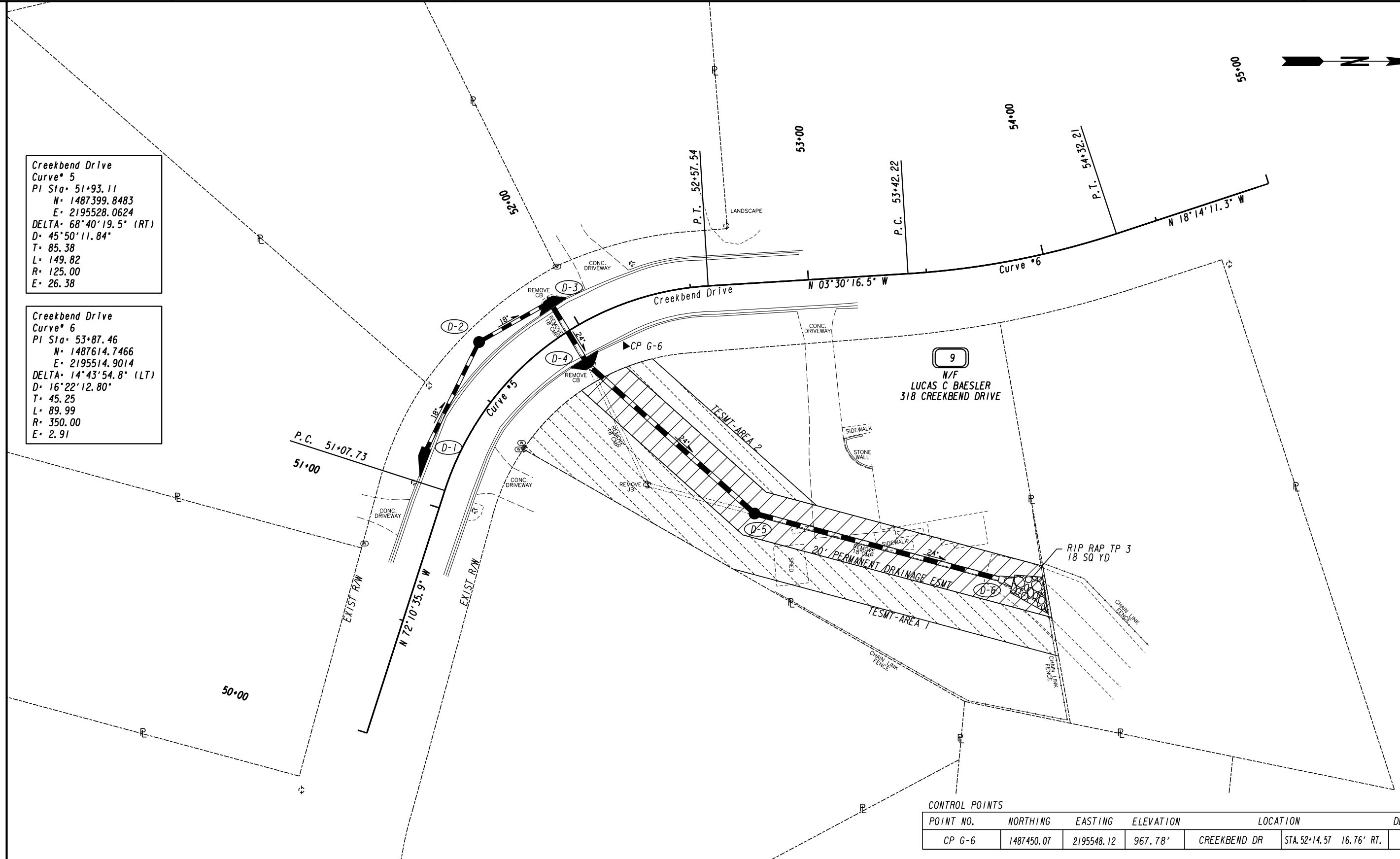

CONTROL POINTS					
POINT NO.	NORTHING	EASTING	ELEVATION	LOCATION	DESCRIPTION
CP G-6	1487450.07	2195548.12	967.78'	CREEKBEND DR STA. 52+14.57	16.76' RT. 60DMAGNL

PROPERTY AND EXISTING R/W LINE
 REQUIRED R/W LINE
 CONSTRUCTION LIMITS
 EASEMENT FOR CONSTR
 & MAINTENANCE OF SLOPES
 EASEMENT FOR CONSTR OF SLOPES
 EASEMENT FOR CONSTR OF DRIVES

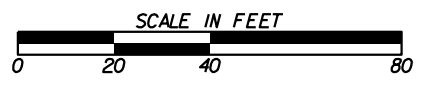
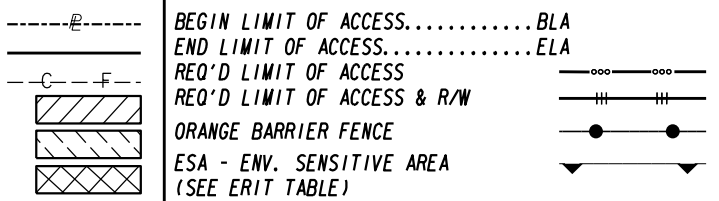

REVISION DATES	

CONSTRUCTION PLAN
 CREEK VIEW
 DRAINAGE IMPROVEMENTS

CHECKED:	DATE:	DRAWING No.
BACKCHECKED:	DATE:	13-0005
CORRECTED:	DATE:	
VERIFIED:	DATE:	

CONTROL POINTS							
POINT NO.	NORTHING	EASTING	ELEVATION	LOCATION		DESCRIPTION	
CP G-7	1488796.59	2195138.20	938.48'	CREEKSIDE LN	STA.74+04.72	16.15' LT.	60DMAGNL



10
N/F
KELLY J KRUER
431 CREEKSIDE LANE

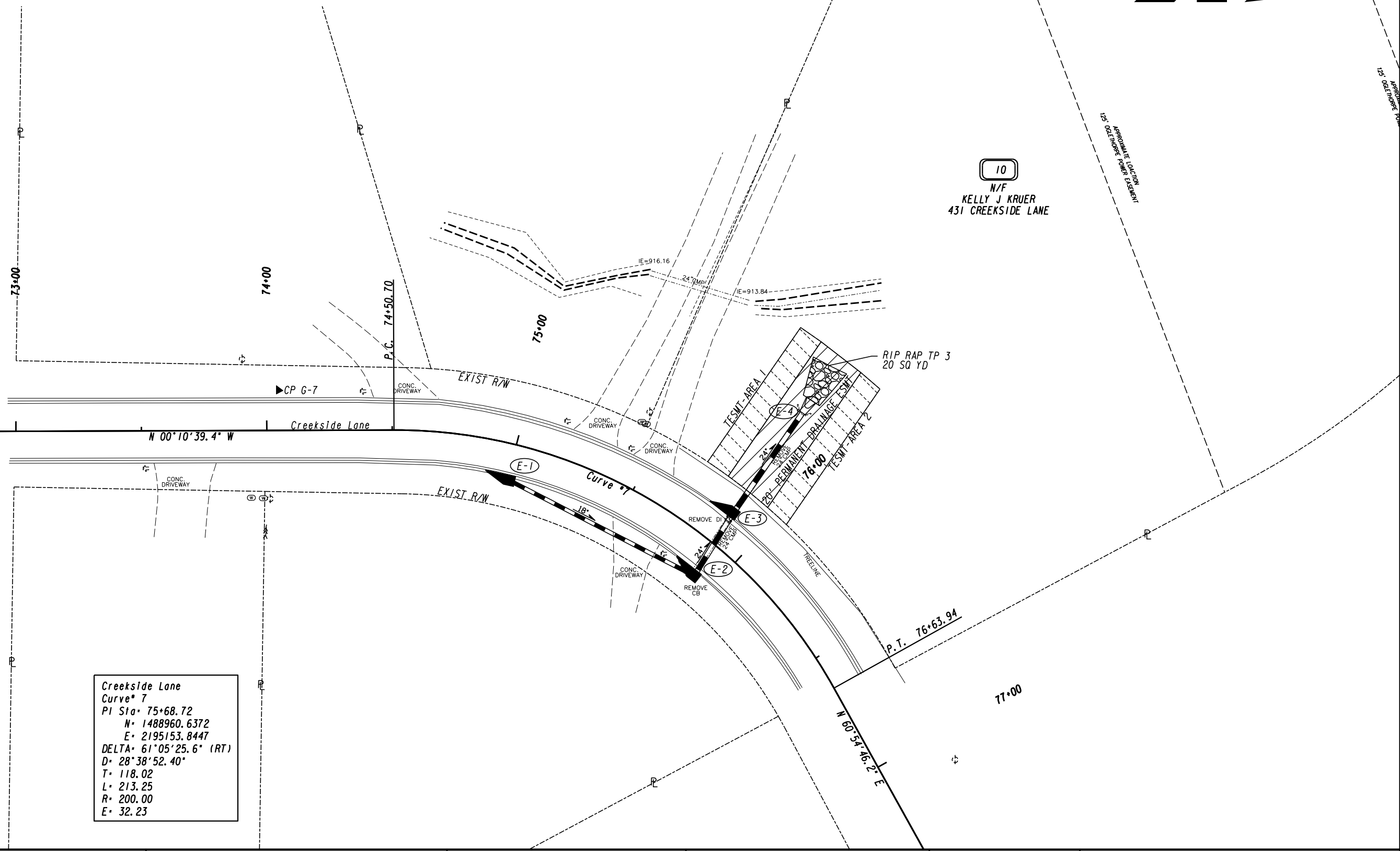

Creekside Lane
Curve 7
PI Sta 75+68.72
N 1488960.6372
E 2195153.8447
DELTA 61°05'25.6" (RT)
D 28°38'52.40"
T 118.02
L 213.25
R 200.00
E 32.23

PROPERTY AND EXISTING R/W LINE
REQUIRED R/W LINE
CONSTRUCTION LIMITS
EASEMENT FOR CONSTR
& MAINTENANCE OF SLOPES
EASEMENT FOR CONSTR OF SLOPES
EASEMENT FOR CONSTR OF DRIVES

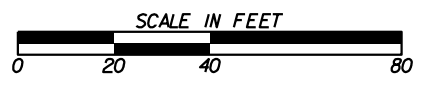
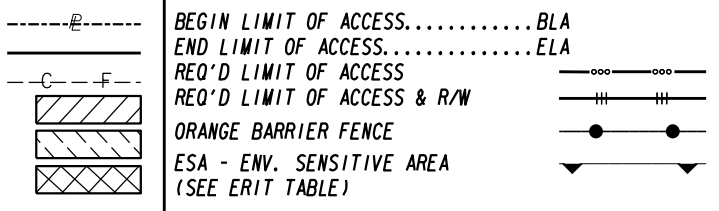

REVISION DATES	

CONSTRUCTION PLAN
CREEK VIEW
DRAINAGE IMPROVEMENTS

CHECKED:	DATE:	DRAWING No.
BACKCHECKED:	DATE:	13-0006
CORRECTED:	DATE:	
VERIFIED:	DATE:	

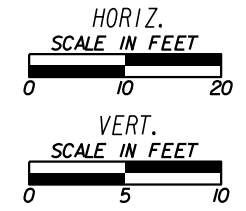
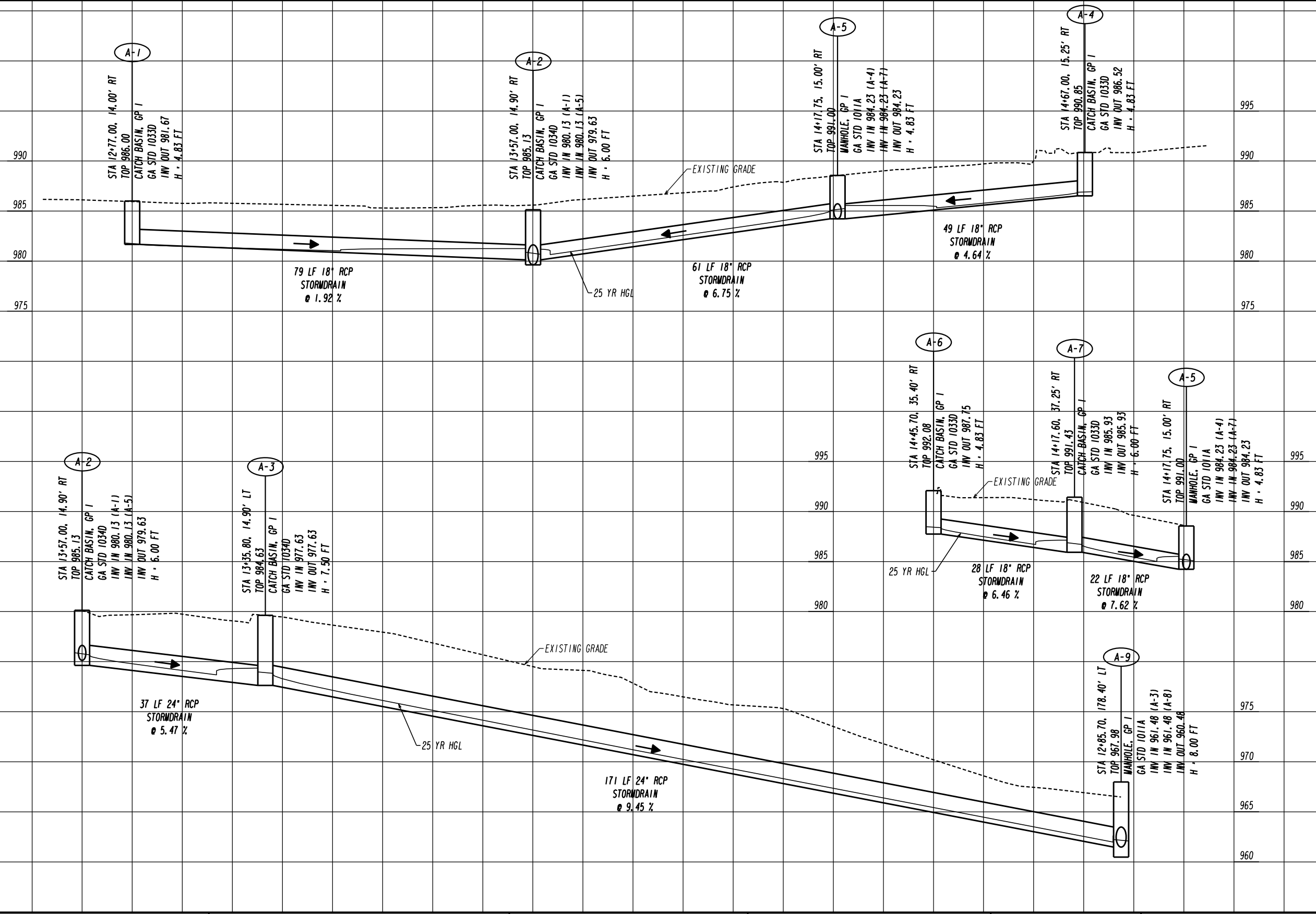

REVISION DATES	

DRAINAGE PROFILES
CREEK VIEW
DRAINAGE IMPROVEMENTS

CHECKED:	DATE:	DRAWING No.
BACKCHECKED:	DATE:	22-0001
CORRECTED:	DATE:	
VERIFIED:	DATE:	

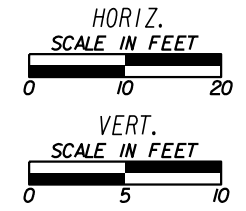
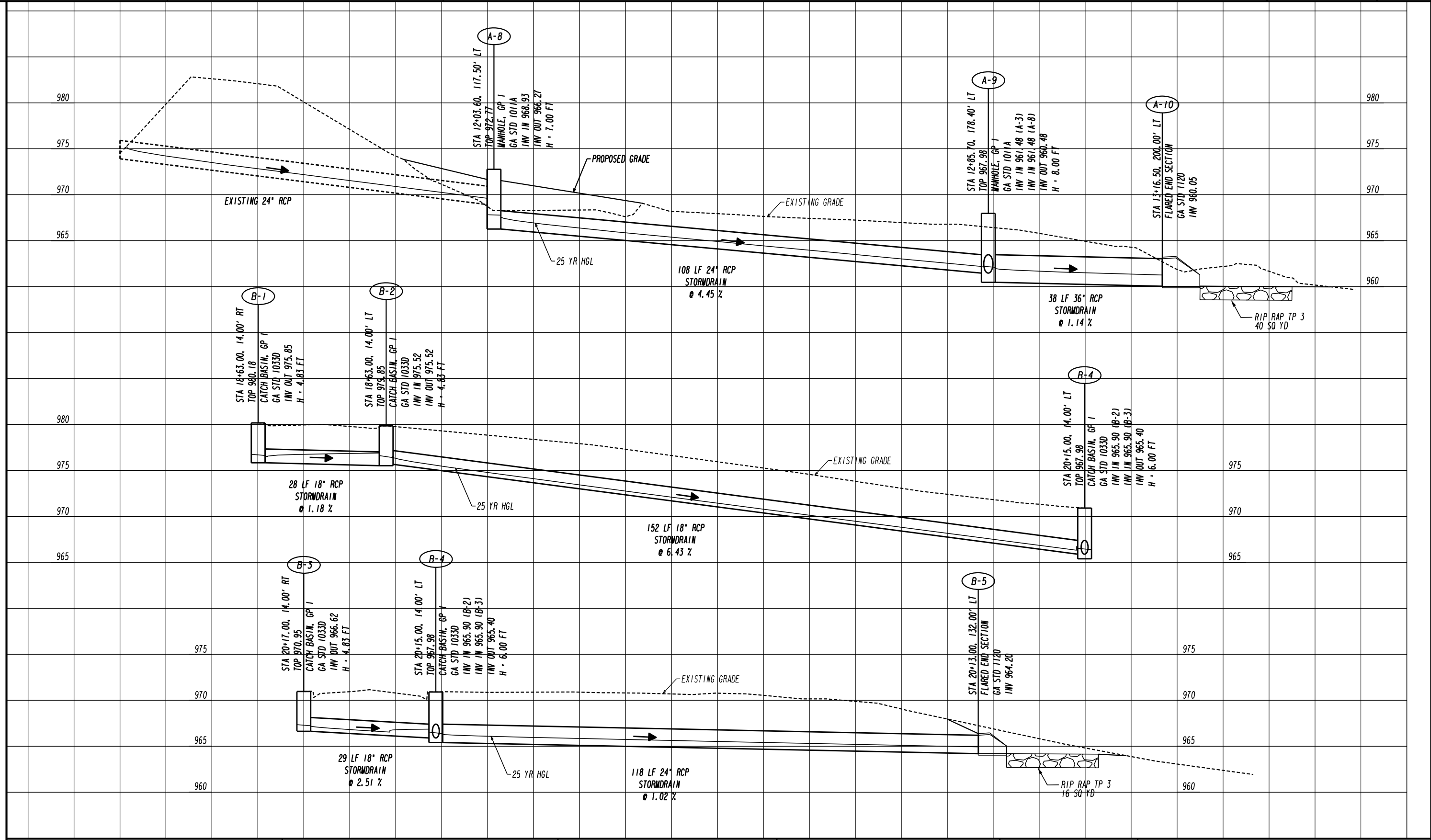

REVISION DATES	

DRAINAGE PROFILES
CREEK VIEW
DRAINAGE IMPROVEMENTS

CHECKED:	DATE:	DRAWING No.
BACKCHECKED:	DATE:	22-0002
CORRECTED:	DATE:	
VERIFIED:	DATE:	

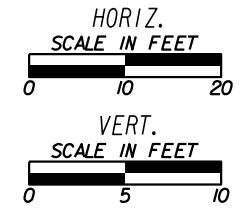
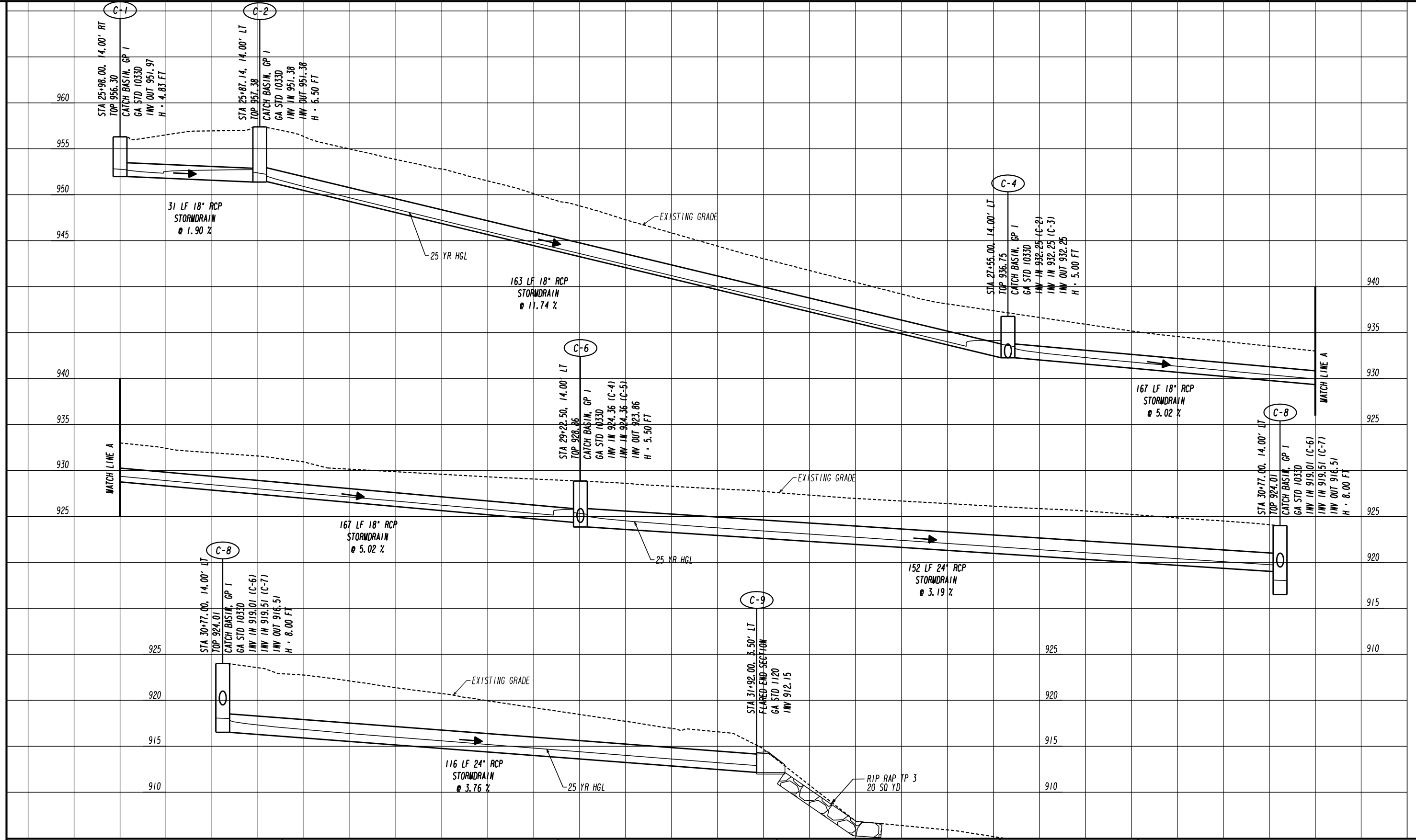

REVISION DATES

REVISION DATES		DRAWING No.	
CHECKED:	DATE:	22-0003	
BACKCHECKED:	DATE:		
CORRECTED:	DATE:		
VERIFIED:	DATE:		

DRAINAGE PROFILES
CREEK VIEW
DRAINAGE IMPROVEMENTS

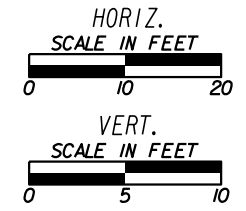
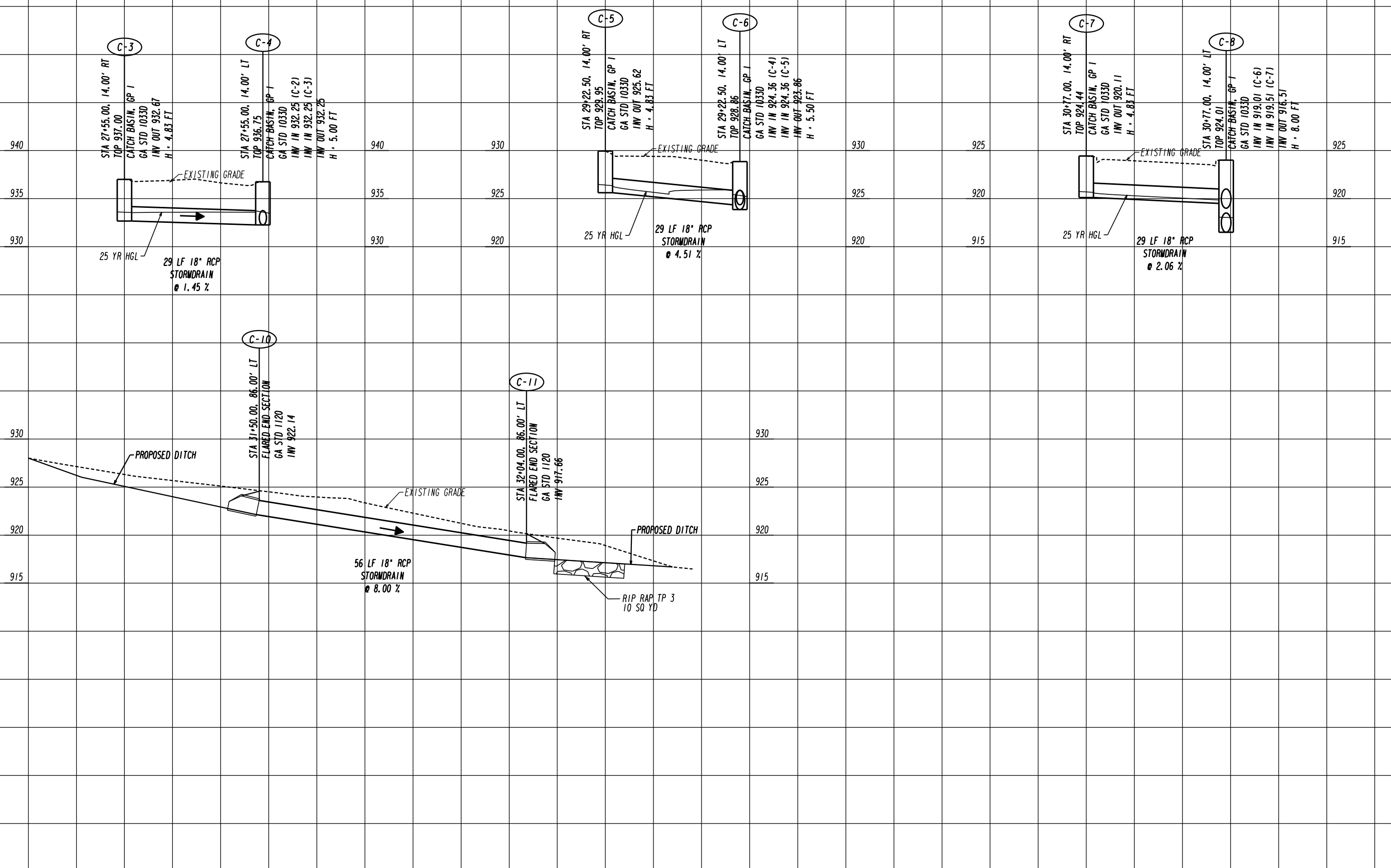

REVISION DATES	

DRAINAGE PROFILES
CREEK VIEW
DRAINAGE IMPROVEMENTS

CHECKED:	DATE:	DRAWING No.
BACKCHECKED:	DATE:	22-0004
CORRECTED:	DATE:	
VERIFIED:	DATE:	

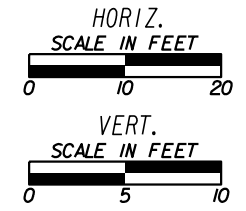
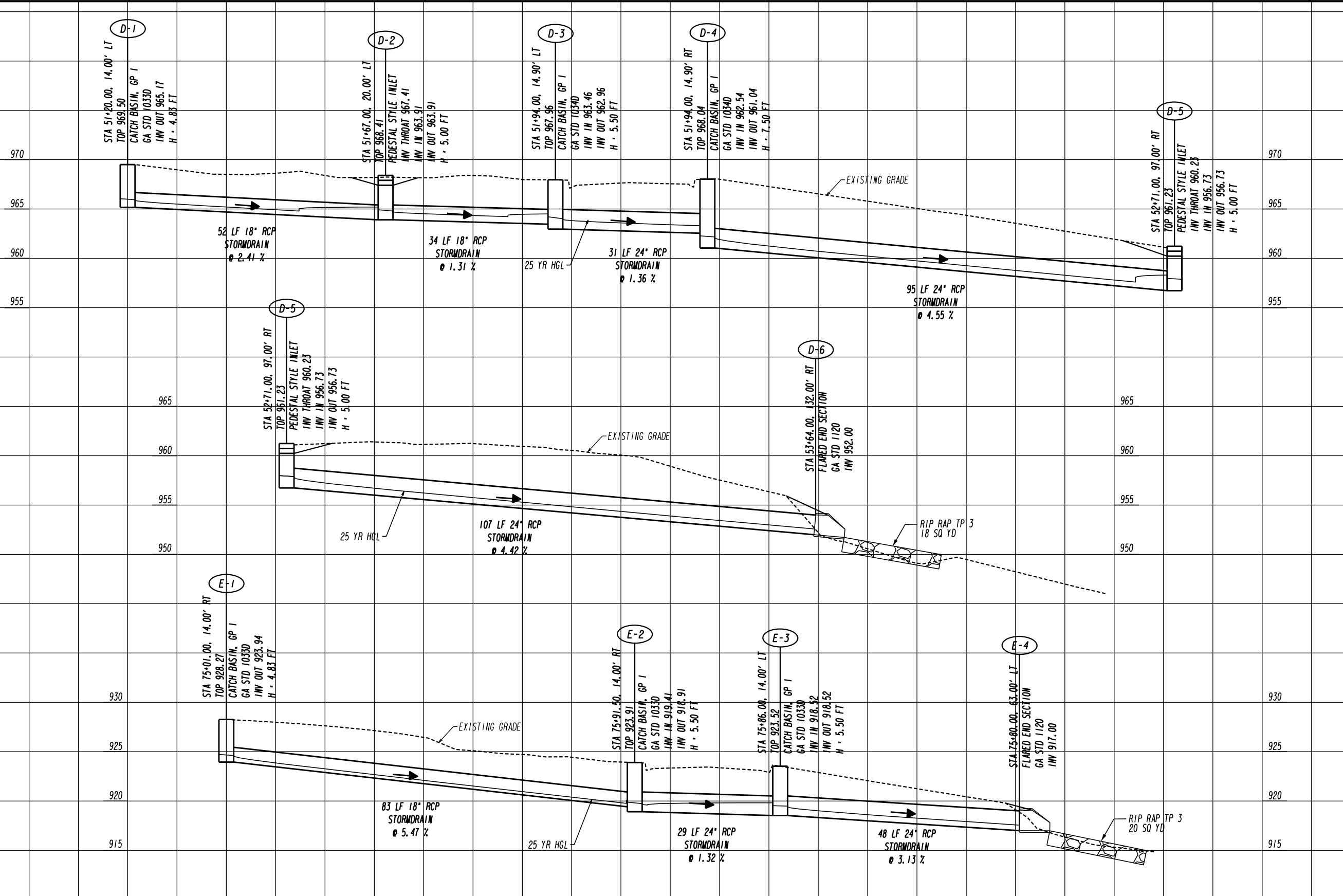

REVISION DATES	

DRAINAGE PROFILES
CREEK VIEW
DRAINAGE IMPROVEMENTS

CHECKED:	DATE:	DRAWING No.
BACKCHECKED:	DATE:	22-0005
CORRECTED:	DATE:	
VERIFIED:	DATE:	

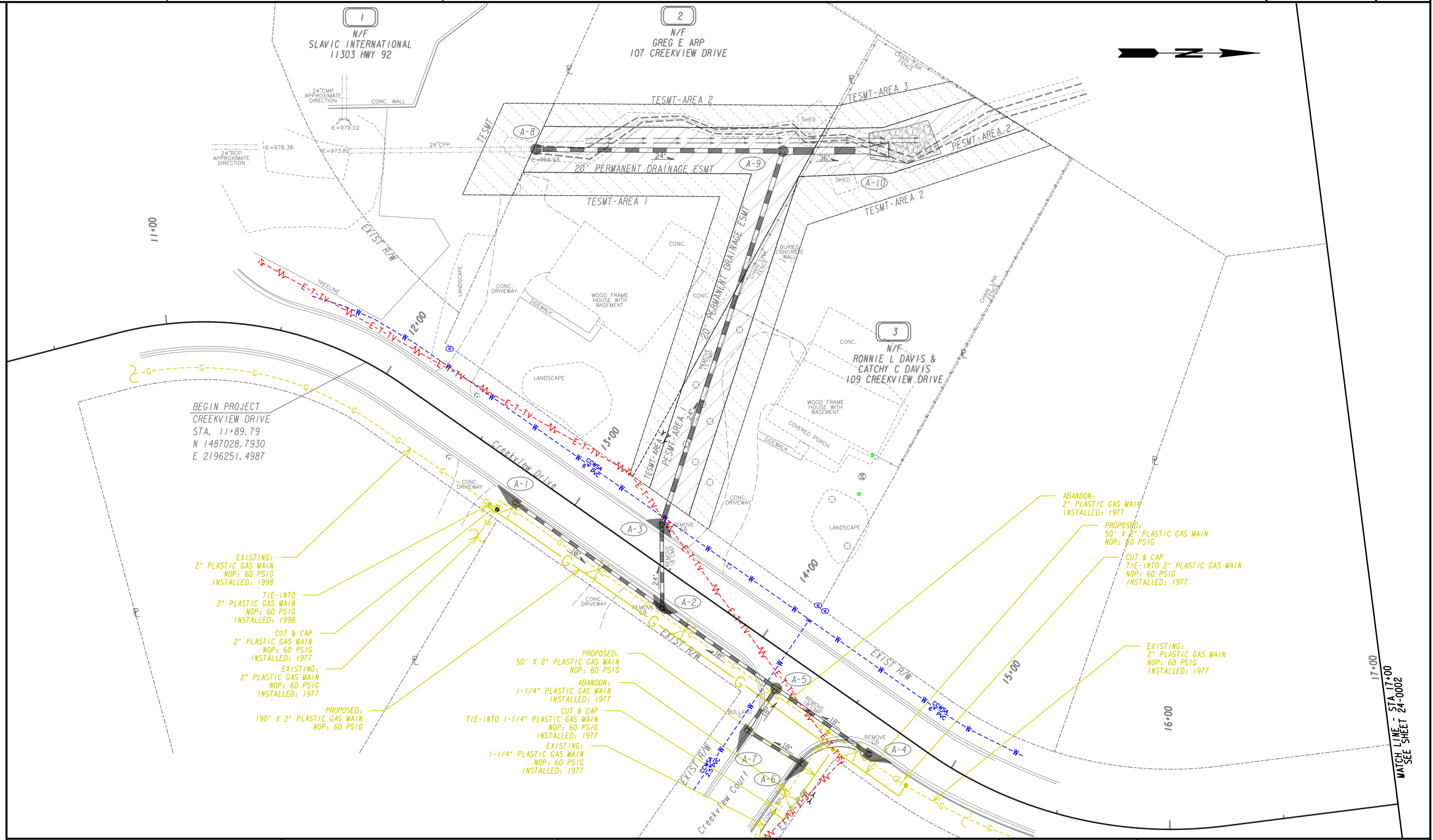

BEGIN PROJECT
CREEKVIEW DRIVE
STA. 11+89.79
N 1487028.7930
E 2196251.4987

EXISTING:
2" PLASTIC GAS MAIN
NOP: 60 PSIG
INSTALLED: 1998

TIE-INTO
2" PLASTIC GAS MAIN
NOP: 60 PSIG
INSTALLED: 1998

CUT & CAP
2" PLASTIC GAS MAIN
NOP: 60 PSIG
INSTALLED: 1977

EXISTING:
2" PLASTIC GAS MAIN
NOP: 60 PSIG
INSTALLED: 1977

PROPOSED:
190' X 2" PLASTIC GAS MAIN
NOP: 60 PSIG

PROPOSED:
50' X 2" PLASTIC GAS MAIN
NOP: 60 PSIG

ABANDON:
1-1/4" PLASTIC GAS MAIN
INSTALLED: 1977

CUT & CAP
TIE-INTO 1-1/4" PLASTIC GAS MAIN
NOP: 60 PSIG
INSTALLED: 1977

EXISTING:
1-1/4" PLASTIC GAS MAIN
NOP: 60 PSIG
INSTALLED: 1977

ABANDON:
2" PLASTIC GAS MAIN
INSTALLED: 1977

PROPOSED:
50' X 2" PLASTIC GAS MAIN
NOP: 60 PSIG

CUT & CAP
TIE-INTO 2" PLASTIC GAS MAIN
NOP: 60 PSIG
INSTALLED: 1977

EXISTING:
2" PLASTIC GAS MAIN
NOP: 60 PSIG
INSTALLED: 1977

PROPERTY AND EXISTING R/W LINE
REQUIRED R/W LINE
CONSTRUCTION LIMITS
EASEMENT FOR CONSTR
& MAINTENANCE OF SLOPES
EASEMENT FOR CONSTR OF SLOPES
EASEMENT FOR CONSTR OF DRIVES

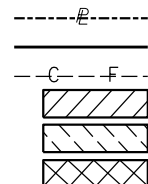

BEGIN LIMIT OF ACCESS.....BLA
END LIMIT OF ACCESS.....ELA
REQ'D LIMIT OF ACCESS
REQ'D LIMIT OF ACCESS & R/W
ORANGE BARRIER FENCE
ESA - ENV. SENSITIVE AREA
(SEE ERIT TABLE)

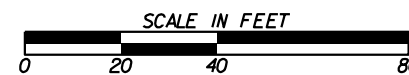

REVISION DATES

NO.	DATE	DESCRIPTION

UTILITY PLAN
CREEK VIEW
DRAINAGE IMPROVEMENTS

CHECKED:	DATE:	DRAWING No.
BACKCHECKED:	DATE:	24-0001
CORRECTED:	DATE:	
VERIFIED:	DATE:	

17+00
MATCH LINE - STA 17+00
SEE SHEET 24-0002



MATCH LINE - STA 17+00
SEE SHEET 24-0001



ABANDON:
2" PLASTIC GAS MAIN
INSTALLED: 1977

CUT & CAP
TIE-INTO 2" PLASTIC GAS MAIN
NOP: 60 PSIG
INSTALLED: 1977

EXISTING:
2" PLASTIC GAS MAIN
NOP: 60 PSIG
INSTALLED: 1977

CUT & CAP
TIE-INTO 2" PLASTIC GAS MAIN
NOP: 60 PSIG
INSTALLED: 1977

PROPOSED:
30" X 2" PLASTIC GAS MAIN
NOP: 60 PSIG

EXISTING:
2" PLASTIC GAS MAIN
NOP: 60 PSIG
INSTALLED: 1977

PROPERTY AND EXISTING R/W LINE
REQUIRED R/W LINE
CONSTRUCTION LIMITS
EASEMENT FOR CONSTR
& MAINTENANCE OF SLOPES
EASEMENT FOR CONSTR OF SLOPES
EASEMENT FOR CONSTR OF DRIVES

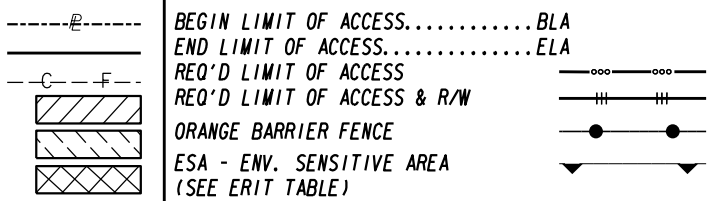

REVISION DATES	

UTILITY PLAN CREEK VIEW DRAINAGE IMPROVEMENTS		
CHECKED:	DATE:	DRAWING No.
BACKCHECKED:	DATE:	24-0002
CORRECTED:	DATE:	
VERIFIED:	DATE:	

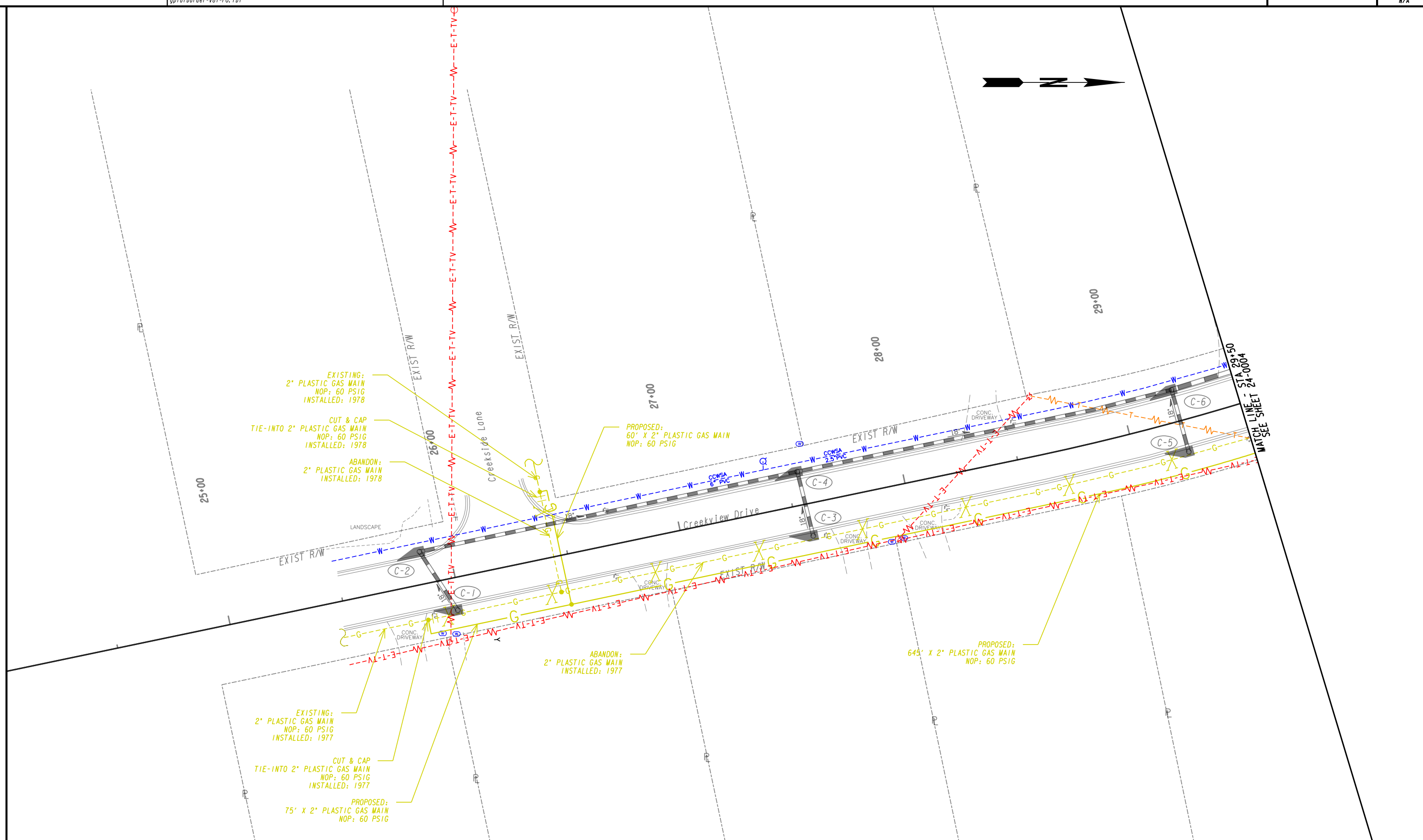

PROPERTY AND EXISTING R/W LINE
 REQUIRED R/W LINE
 CONSTRUCTION LIMITS
 EASEMENT FOR CONSTR
 & MAINTENANCE OF SLOPES
 EASEMENT FOR CONSTR OF SLOPES
 EASEMENT FOR CONSTR OF DRIVES

-----e-----
 ---C---F---
 [Hatched Box]
 [Hatched Box]
 [Hatched Box]

BEGIN LIMIT OF ACCESS.....BLA
 END LIMIT OF ACCESS.....ELA
 REQ'D LIMIT OF ACCESS
 REQ'D LIMIT OF ACCESS & R/W
 ORANGE BARRIER FENCE
 ESA - ENV. SENSITIVE AREA
 (SEE ERIT TABLE)

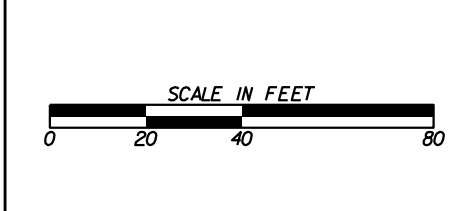

REVISION DATES	

UTILITY PLAN
 CREEK VIEW
 DRAINAGE IMPROVEMENTS

CHECKED:	DATE:	DRAWING No.
BACKCHECKED:	DATE:	24-0003
CORRECTED:	DATE:	
VERIFIED:	DATE:	

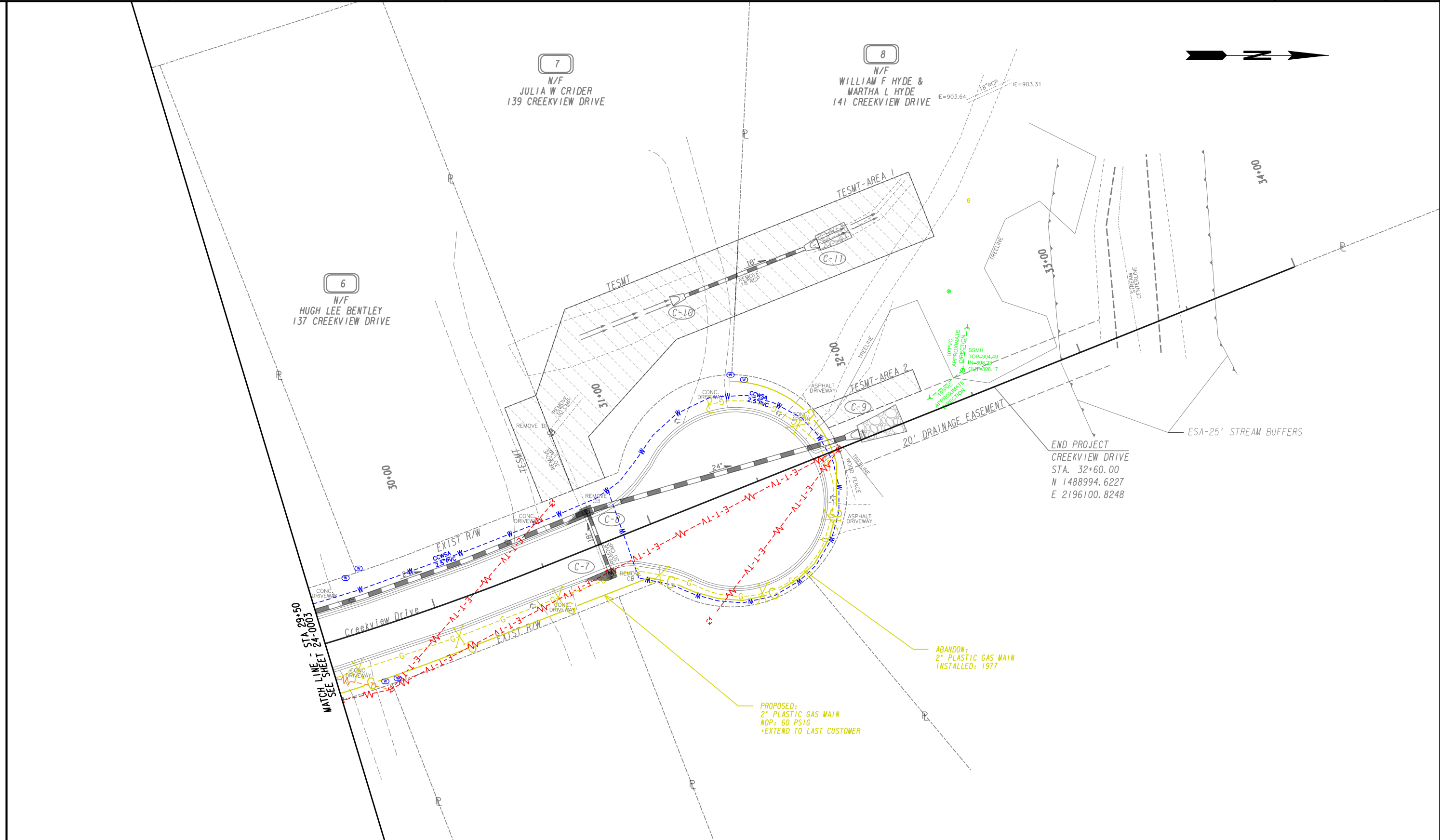

PROPERTY AND EXISTING R/W LINE
 REQUIRED R/W LINE
 CONSTRUCTION LIMITS
 EASEMENT FOR CONSTR
 & MAINTENANCE OF SLOPES
 EASEMENT FOR CONSTR OF SLOPES
 EASEMENT FOR CONSTR OF DRIVES

-----e-----
 BEGIN LIMIT OF ACCESS.....BLA
 END LIMIT OF ACCESS.....ELA
 ---C---F---
 REQ'D LIMIT OF ACCESS
 REQ'D LIMIT OF ACCESS & R/W
 ORANGE BARRIER FENCE
 ESA - ENV. SENSITIVE AREA
 (SEE ERIT TABLE)

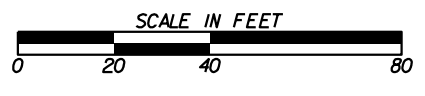

REVISION DATES	

UTILITY PLAN CREEK VIEW DRAINAGE IMPROVEMENTS		
CHECKED:	DATE:	DRAWING No.
BACKCHECKED:	DATE:	24-0004
CORRECTED:	DATE:	
VERIFIED:	DATE:	

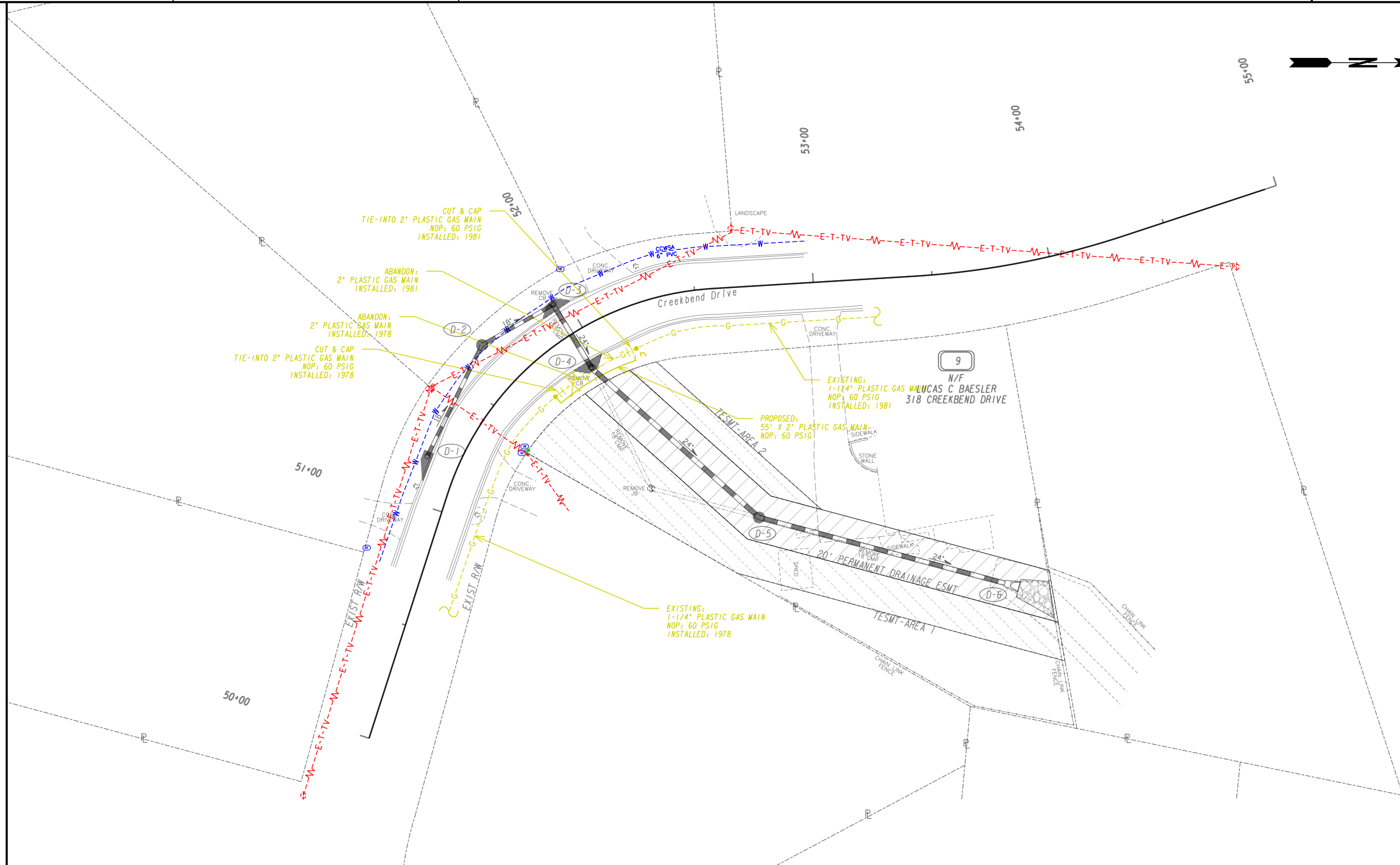

PROPERTY AND EXISTING R/W LINE
 REQUIRED R/W LINE
 CONSTRUCTION LIMITS
 EASEMENT FOR CONSTR
 & MAINTENANCE OF SLOPES
 EASEMENT FOR CONSTR OF SLOPES
 EASEMENT FOR CONSTR OF DRIVES

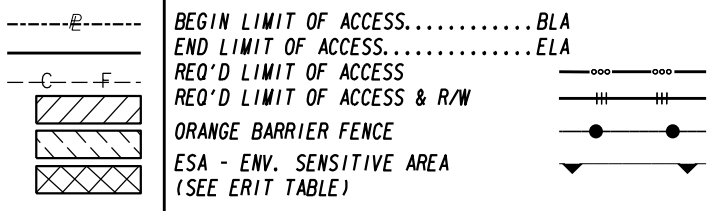

REVISION DATES	

UTILITY PLAN
CREEK VIEW
DRAINAGE IMPROVEMENTS

CHECKED:	DATE:	DRAWING No.
BACKCHECKED:	DATE:	24-0005
CORRECTED:	DATE:	
VERIFIED:	DATE:	



10
N/F
KELLY J KRUER
431 CREEKSIDE LANE

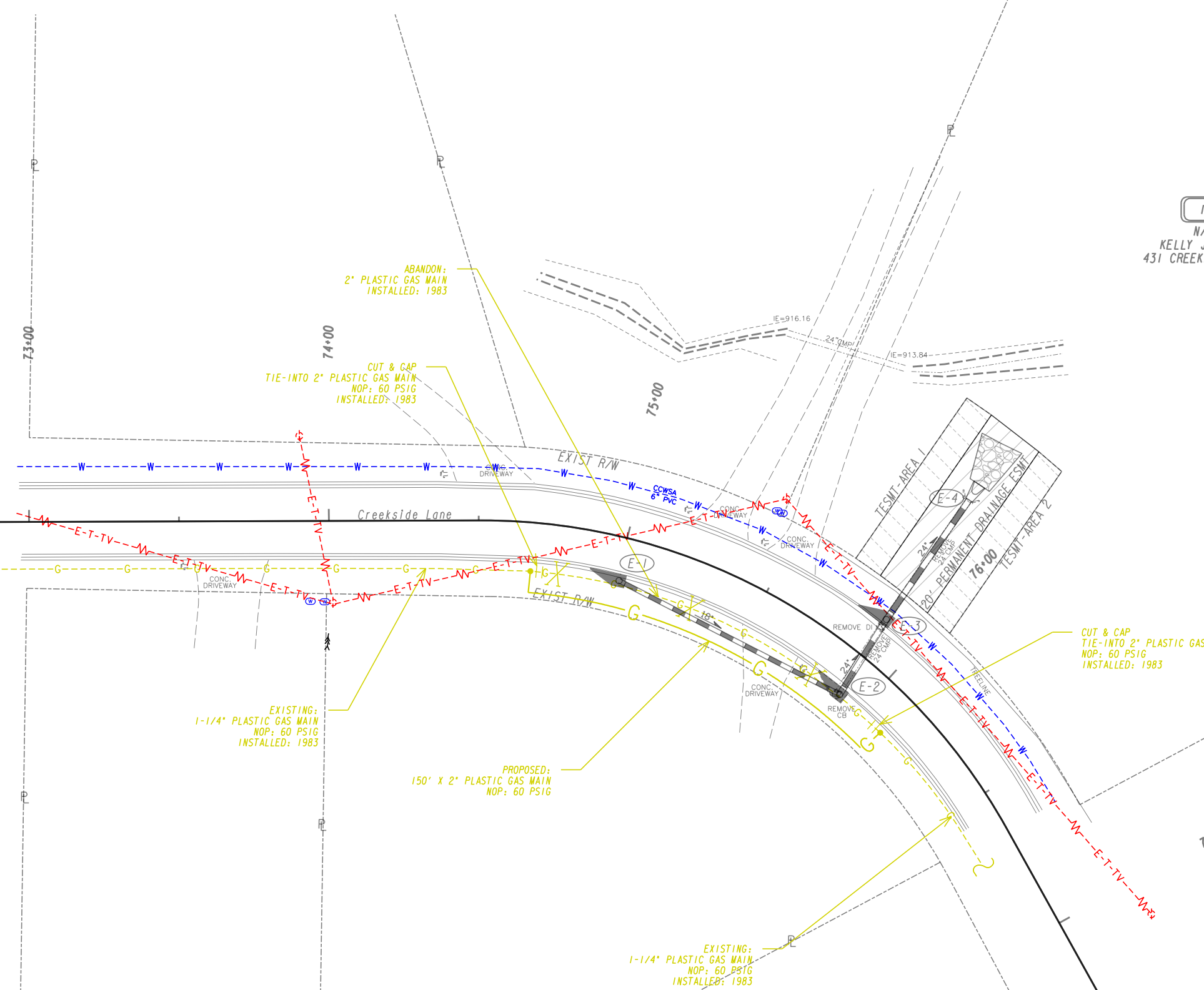

ABANDON:
2" PLASTIC GAS MAIN
INSTALLED: 1983

CUT & CAP
TIE-INTO 2" PLASTIC GAS MAIN
NOP: 60 PSIG
INSTALLED: 1983

CUT & CAP
TIE-INTO 2" PLASTIC GAS MAIN
NOP: 60 PSIG
INSTALLED: 1983

EXISTING:
1-1/4" PLASTIC GAS MAIN
NOP: 60 PSIG
INSTALLED: 1983

PROPOSED:
150' X 2" PLASTIC GAS MAIN
NOP: 60 PSIG

EXISTING:
1-1/4" PLASTIC GAS MAIN
NOP: 60 PSIG
INSTALLED: 1983

PROPERTY AND EXISTING R/W LINE
REQUIRED R/W LINE
CONSTRUCTION LIMITS
EASEMENT FOR CONSTR
& MAINTENANCE OF SLOPES
EASEMENT FOR CONSTR OF SLOPES
EASEMENT FOR CONSTR OF DRIVES

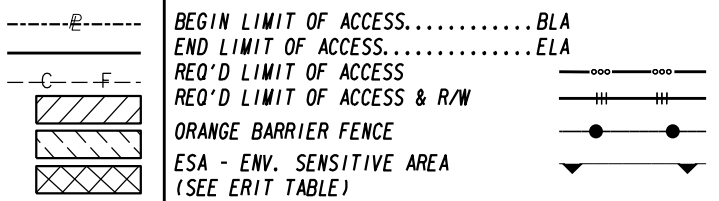



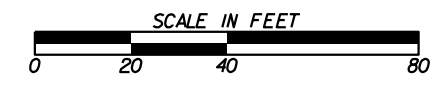





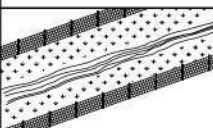

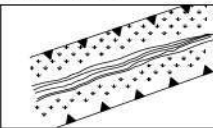

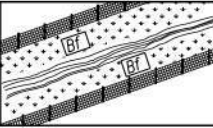

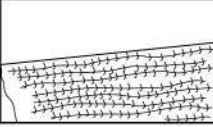

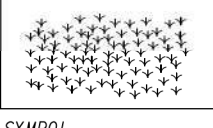

BEGIN LIMIT OF ACCESS.....BLA
END LIMIT OF ACCESS.....ELA
REQ'D LIMIT OF ACCESS
REQ'D LIMIT OF ACCESS & R/W
ORANGE BARRIER FENCE
ESA - ENV. SENSITIVE AREA
(SEE ERIT TABLE)

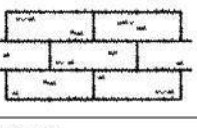

REVISION DATES	

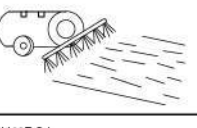
UTILITY PLAN CREEK VIEW DRAINAGE IMPROVEMENTS		
CHECKED:	DATE:	DRAWING No.
BACKCHECKED:	DATE:	24-0006
CORRECTED:	DATE:	
VERIFIED:	DATE:	

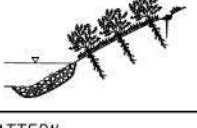
CODE	PRACTICE STD OR DETAIL SPEC. SECT.	DETAIL	DESCRIPTION
	ORANGE BARRIER FENCE		ORANGE BARRIER FENCE DELINEATES ENVIRONMENTALLY SENSITIVE AREAS WHERE THE CONTRACTOR SHALL NOT CLEAR, GRUB, OR PLACE CONSTRUCTION MATERIALS OR EQUIPMENT WITHIN THIS AREA.
	LINE CODE		
ESA	ENVIRONMENTALLY SENSITIVE AREA		AN ENVIRONMENTALLY SENSITIVE AREA (ESA) CONTAINS RESOURCES THAT ARE ENVIRONMENTALLY, CULTURALLY, OR HISTORICALLY SENSITIVE. ESAs INCLUDE, BUT ARE NOT LIMITED TO: STATE WATER BUFFERS, HISTORIC SITES, ARCHAEOLOGICAL SITES, AND PROTECTED ANIMAL AND PLANT SPECIES HABITATS. IF WORK IS AUTHORIZED IN THIS AREA, THE WORK MUST BE PERFORMED IN ACCORDANCE WITH SECTION 107 AND ANY OTHER APPLICABLE SPECIAL PROVISIONS AND APPLICABLE PLAN NOTES.
	LINE CODE		
	ESAs-25' (OR 50') STREAM BUFFER, ETC.		
Bf	BUFFER ZONE		A STRIP OF UNDISTURBED ORIGINAL VEGETATION, ENHANCED OR RESTORED EXISTING VEGETATION, OR THE RE-ESTABLISHMENT OF VEGETATION SURROUNDING AN AREA OF DISTURBANCE OR BORDERING STREAMS, PONDS, WETLANDS, LAKES, AND COASTAL WATERS. WHEN NECESSARY, BUFFER ZONES ARE TO BE PROTECTED BY ORANGE BARRIER FENCE.
	SYMBOL		
Ds1	MULCH SECTION 163		THIS IS AN APPLICATION OF STRAW MULCH USED TO REDUCE SOIL EROSION AND STABILIZE THE SOIL. IT IS USED TO CONTROL EROSION IN AREAS WHERE PERMANENT VEGETATION IS OUT OF SEASON OR TO TEMPORARILY STABILIZE AREAS PRIOR TO FINAL GRADING. MULCHING REQUIREMENTS ARE ADDRESSED BY STANDARD SPECIFICATIONS AND/OR THE PROJECT ENGINEER. THE BMP SYMBOL FOR APPLICABLE AREAS AND/OR A NOTE SHALL BE INCLUDED ON APPLICABLE SHEETS IN SECTION 54.
	SYMBOL		
Ds2	TEMPORARY GRASSING SECTION 163, 700		THE SOWING OF A QUICK GROWING SPECIES OF GRASS SUITABLE TO THE AREA AND SEASON. IT IS TYPICALLY USED TO CONTROL EROSION IN AREAS LONGER THAN MULCHING IS EXPECTED TO LAST. TEMPORARY GRASSING SHOULD BE USED ON ALL PROJECTS ACCORDING TO THE STANDARD SPECIFICATIONS. THE BMP SYMBOL FOR APPLICABLE AREAS AND/OR A NOTE SHALL BE INCLUDED ON APPLICABLE SHEETS IN SECTION 54.
	SYMBOL		

CODE	PRACTICE STD OR DETAIL SPEC. SECT.	DETAIL	DESCRIPTION
Ds3	PERMANENT GRASSING SECTION 700		THE SOWING OF PERMANENT VEGETATION, SUCH AS GRASS, SUITABLE TO THE AREA AND SEASON. PERMANENT VEGETATION SHALL BE USED ON ALL PROJECTS ACCORDING TO THE STANDARD SPECIFICATION. THE BMP SYMBOL FOR APPLICABLE AREAS AND/OR A NOTE SHALL BE INCLUDED ON APPLICABLE SHEETS IN SECTION 54.
	SYMBOL		
Ds4	SODDING CONSTRUCTION DETAIL D-54 SECTION 700, 890		THE INSTALLATION OF A SPECIES OF GRASS SODDING SUITABLE TO THE AREA AND SEASON TO PROVIDE IMMEDIATE PERMANENT VEGETATION. SODDING MAY BE SHOWN FOR HIGHLY SENSITIVE AREAS, TO IMPROVE AESTHETICS, OR FOR SPECIAL PLANTING REQUIREMENTS ON THE BASIS OF ENVIRONMENTAL COMMITMENTS OR LANDSCAPING REQUIREMENTS. THE BMP PATTERN FOR APPLICABLE AREAS AND/OR A NOTE SHALL BE INCLUDED ON APPLICABLE SHEETS IN SECTION 54.
	PATTERN		
Fi-Co	FLOCCULANTS COAGULANTS SECTION 163, 700, 895		FLOCCULANTS AND COAGULANTS ARE USED TO SETTLE SUSPENDED SEDIMENT, HEAVY METALS, AND HYDROCARBONS (TSS) IN SLOW MOVING RUNOFF FROM CONSTRUCTION SITES FOR WATER CLARIFICATION. ANIONIC POLYACRYLAMIDES (PAM) MAY BE USED IN CONJUNCTION WITH BMPs WITHIN CHANNELS UPSTREAM OF A POST-CONSTRUCTION POND, TEMPORARY SEDIMENT BASIN, OR TEMPORARY SEDIMENT TRAP. FLOCCULANTS SHALL NOT BE USED DOWNSTREAM OF AFOREMENTIONED BMPs! FLOCCULANTS/COAGULANTS ARE TO BE SHOWN ON PLANS WITH APPLICABLE BMP IF NEEDED. PAYMENT FOR PAM AS A FLOCCULANT WILL BE INCLUDED IN THE PRICE FOR THE INSTALLATION AND/OR MAINTENANCE OF THE BMP IT IS USED IN CONJUNCTION WITH. NO SEPARATE PAYMENT WILL BE MADE.
	SYMBOL		
	POLYACRYLAMIDE		
Sb	STREAMBANK STABILIZATION SECTION 702		STREAMBANK STABILIZATION IS THE USE OF READILY AVAILABLE NATIVE PLANT MATERIALS TO MAINTAIN AND ENHANCE STREAMBANKS, OR TO PREVENT, OR RESTORE AND REPAIR SMALL STREAMBANK EROSION PROBLEMS. STREAMBANK STABILIZATION AREAS SHOULD BE SHOWN ON THE PLANS WHEN APPLICABLE TO THE PROJECT. REFER TO THE PROJECT'S STREAM AND STREAM BUFFER MITIGATION PLANS FOR PLANT SPECIES, LOCATIONS, AND OTHER PLANTING DETAILS.
	PATTERN		

NOTE:

- DO NOT USE EROSION CONTROL ITEMS IN A FLOWING STREAM OR IN A TIDAL AREA BELOW HIGH TIDE.
- FOR ADDITIONAL INFORMATION ON THE DESIGN AND APPLICATION OF EROSION AND SEDIMENT CONTROL BEST MANAGEMENT PRACTICES (BMPs), REFER TO THE LATEST EDITION OF THE GEORGIA SOIL AND WATER CONSERVATION COMMISSION'S, "MANUAL FOR EROSION AND SEDIMENT CONTROL IN GEORGIA".



NO SCALE

REVISION DATES		EROSION CONTROL LEGEND	
3/2/2017		UNIFORM CODE SHEET	
		SHEET 1 OF 7	
CHECKED:	D. EARLETON	DATE:	01/01/16
BACKCHECKED:		DATE:	
CORRECTED:		DATE:	
VERIFIED:		DATE:	
		DRAWING No.	
		52-0001	



REVISION DATES		EROSION CONTROL LEGEND	
		CREEK VIEW	
		DRAINAGE IMPROVEMENTS	
CHECKED:		DATE:	
BACKCHECKED:		DATE:	
CORRECTED:		DATE:	
VERIFIED:		DATE:	
		DRAWING No.	
		52-0001	

CODE	PRACTICE STD OR DETAIL SPEC. SECT.	DETAIL	DESCRIPTION
Ss	SLOPE STABILIZATION CONSTRUCTION DETAIL D-35 SECTION 716		SLOPE STABILIZATION (EROSION CONTROL MATTING) IS A PROTECTIVE COVERING USED TO PREVENT EROSION AND ESTABLISH TEMPORARY OR PERMANENT VEGETATION ON STEEP SLOPES, SHORE LINES, OR CHANNELS. SLOPE STABILIZATION MAY BE A ROLLED EROSION CONTROL PRODUCT (RECP) OR A HYDRAULIC EROSION CONTROL PRODUCT (HECP). SLOPE STABILIZATION SHALL BE USED ON ALL CUT OR FILL SLOPES OF 2.5:1 OR STEEPER AND WITHIN 50 FEET OF ALL CROSS DRAINS AND CULVERTS. NOTE: ONLY COCONUT FIBER BLANKET OR WOOD FIBER BLANKET SHALL BE USED AS SLOPE STABILIZATION WITHIN BUFFERED AREAS.
		PATTERN 	
TAC	TACKIFIERS SECTION 163, 700, 895		TACKIFIERS HYDRATE IN WATER AND READILY BLEND WITH OTHER SLURRY MATERIALS AND ARE USED TO TIE-DOWN FOR SOIL, COMPOST, SEED, STRAW, HAY OR MULCH. TACKIFIERS REQUIREMENTS, SUCH AS ANIONIC POLYACRYLAMIDES (PAM) ARE ADDRESSED BY STANDARD SPECIFICATIONS AND ARE NOT TYPICALLY SHOWN ON THE PLANS. PAM IS TYPICALLY USED BY THE CONTRACTOR FOR TEMPORARY OR PERMANENT GRASSING. REFER TO THE LATEST EDITION OF THE "MANUAL FOR EROSION AND SEDIMENT CONTROL IN GEORGIA" FOR CRITERIA.
		SYMBOL POLYACRYLAMIDE	
Cd-F	FABRIC CHECK DAM CONSTRUCTION DETAIL D-24D SECTION 171		A CHECK DAM COMPOSED OF SYNTHETIC FIBER FABRIC, WIRE REINFORCED, POST, OVERFLOW WEIR, AND TURF REINFORCEMENT MATTING (TRM) SPLASHPAD PLACED IN DITCHES IN A SPECIAL CONFIGURATION WHICH CONTROLS ENERGY DISSIPATION AND FILTRATION OF STORM WATER. SEE CONSTRUCTION DETAIL D-24D FOR ADDITIONAL INFORMATION AND SPACING REQUIREMENTS. THIS ITEM IS SUITABLE FOR USE IN ROADSIDE DITCHES THAT ARE PART OF INFRASTRUCTURE CONSTRUCTION PROJECTS AND WITHIN THE CLEAR ZONE. IF THIS ITEM IS USED IN AN AREA WITH FLOWS GREATER THAN 2.0-CFS OR WITHOUT A SEDIMENT BASIN, A MINIMUM OF ONE ROCK FILTER DAM SHALL BE USED AT THE DOWNSTREAM DISCHARGE POINT.
		SYMBOL 	
Cd-Fs	COMPOST FILTER SOCK CHECK DAM CONSTRUCTION DETAIL D-52 SECTION 163		A COMPOST FILTER SOCK CHECK DAM IS COMPOSED OF A PHOTODEGRADABLE OR BIODEGRADABLE KNITTED MESH MATERIAL CONTAINING A WEED FREE FILLER MATERIAL DERIVED FROM A WELL-DECOMPOSED SOURCE OF ORGANIC MATTER. THEY SHALL BE PROPERLY STAKED FOR DITCH APPLICATIONS. REFER TO THE LATEST EDITION OF THE "MANUAL FOR EROSION AND SEDIMENT CONTROL IN GEORGIA" FOR MATERIAL SPECIFICATIONS. IF THIS ITEM IS USED IN AN AREA WITH FLOWS GREATER THAN 2.0-CFS OR WITHOUT A SEDIMENT BASIN, A MINIMUM OF ONE ROCK FILTER DAM SHALL BE USED AT THE DOWNSTREAM DISCHARGE POINT.
		SYMBOL 	
Cd-Hb	BALED STRAW CHECK DAM CONSTRUCTION DETAIL D-52 SECTION 163		A BALE STRAW CHECK DAM IS COMPOSED OF BALES PREFERABLY BOUND WITH WIRE OR NYLON INSTEAD OF TWINE. BALES SHOULD BE PLACED IN ROWS WITH BALE ENDS TIGHTLY ABUTTING ADJACENT BALES. THE DOWNSTREAM ROW OF BALES SHALL BE PLACED IN A TRENCH TO ALLOW THE TOP OF THE BALE'S LONG, WIDE SIDE TO BE LEVEL WITH THE GROUND AS A NON-ERODIBLE SPLASHPAD. PROPER STAKING IS ALSO REQUIRED FOR DITCH APPLICATIONS. IF THIS ITEM IS USED IN AN AREA WITH FLOWS GREATER THAN 2.0-CFS OR WITHOUT A SEDIMENT BASIN, A MINIMUM OF ONE ROCK FILTER DAM SHALL BE USED AT THE DOWNSTREAM DISCHARGE POINT.
		SYMBOL 	

CODE	PRACTICE STD OR DETAIL SPEC. SECT.	DETAIL	DESCRIPTION
Cd-S	STONE CHECK DAM OR SANDBAG CHECK DAM CONSTRUCTION DETAIL D-56 SECTION 163.603		STONE CHECK DAMS ARE CONSTRUCTED OF TYPE-3 RIP-RAP WITH GEOTEXTILE UNDERLINER. STONE CHECK DAMS ARE PREFERRED IN ROADWAY DITCHES OUTSIDE THE CLEAR ZONE. CONSIDERATION SHOULD BE GIVEN TO USING OTHER APPROPRIATE CHECK DAMS AND/OR BMPs WITHIN THE CLEAR ZONE. SANDBAG CHECK DAMS ARE RECOMMENDED IN CONCRETE LINED CHANNELS FOR TEMPORARY VELOCITY CONTROL ONLY. ENSURE DISCHARGE POINT IS PROPERLY STABILIZED AND INCLUDE APPROPRIATE BMPs FOR SEDIMENT STORAGE UPSTREAM AND/OR DOWNSTREAM OF CONCRETE LINED CHANNELS. IF THIS ITEM IS USED IN AN AREA WITH FLOWS GREATER THAN 2.0-CFS OR WITHOUT A SEDIMENT BASIN, A MINIMUM OF ONE ROCK FILTER DAM SHALL BE USED AT THE DOWNSTREAM DISCHARGE POINT.
		SYMBOL 	
Ch-1	VEGETATED CHANNEL STABILIZATION SECTION 700		A NEW OR EXISTING CHANNEL MAY BE LINED WITH PERMANENT VEGETATION ONLY FOR VELOCITIES UP TO 5.0 fps. THIS MEASURE SHALL BE DESIGNED IN ACCORDANCE WITH THE GDOT CHANNEL LINING DESIGN PROGRAM. ADDITIONAL EROSION CONTROL MEASURES MAY BE REQUIRED. TYPICALLY NOT SHOWN IN PLANS.
		LINE CODE 	
Ch-2R1	CHANNEL STABILIZATION RIP-RAP, TYPE 1 CONSTRUCTION DETAIL D-49 SECTION 603		THIS ITEM CONSISTS OF LINING A CHANNEL WITH TYPE 1 RIP-RAP 24" THICK (UNLESS SPECIFIED OTHERWISE) PLACED ON TOP OF A GEOTEXTILE UNDERLINER. THE RIP-RAP SHALL PROTECT THE CHANNEL FLOWING TO A DEPTH "Dp" RECOMMENDED BY THE GDOT CHANNEL LINING PROGRAM. ADDITIONAL EROSION CONTROL MEASURES MAY BE REQUIRED. *Dp* SHALL BE IDENTIFIED IN A TABLE LOCATED ON THE SUMMARY OF QUANTITIES SHEETS AND IN THE EROSION, SEDIMENTATION, AND POLLUTION CONTROL PLAN.
		LINE CODE 	
Ch-2R3	CHANNEL STABILIZATION RIP-RAP, TYPE 3 CONSTRUCTION DETAIL D-49 SECTION 603		THIS ITEM CONSISTS OF LINING A CHANNEL WITH TYPE 3 RIP-RAP 24" THICK (UNLESS SPECIFIED OTHERWISE) PLACED ON TOP OF A GEOTEXTILE UNDERLINER. THE RIP-RAP SHALL PROTECT THE CHANNEL FLOWING TO A DEPTH "Dp" RECOMMENDED BY THE GDOT CHANNEL LINING PROGRAM. ADDITIONAL EROSION CONTROL MEASURES MAY BE REQUIRED. *Dp* SHALL BE IDENTIFIED IN A TABLE LOCATED ON THE SUMMARY OF QUANTITIES SHEETS AND IN THE EROSION, SEDIMENTATION, AND POLLUTION CONTROL PLAN.
		LINE CODE 	

NOTE:
 1. DO NOT USE EROSION CONTROL ITEMS IN A FLOWING STREAM OR IN A TIDAL AREA BELOW HIGH TIDE.
 2. FOR ADDITIONAL INFORMATION ON THE DESIGN AND APPLICATION OF EROSION AND SEDIMENT CONTROL BEST MANAGEMENT PRACTICES (BMPs), REFER TO THE LATEST EDITION OF THE GEORGIA SOIL AND WATER CONSERVATION COMMISSION'S, "MANUAL FOR EROSION AND SEDIMENT CONTROL IN GEORGIA".

GDOT

NO SCALE

REVISION DATES	
3/2/2017	
11/28/2018	

EROSION CONTROL LEGEND			
UNIFORM CODE SHEET			
SHEET 2 OF 7			
CHECKED:	D. EAGLETON	DATE:	01/01/16
BACKCHECKED:		DATE:	
CORRECTED:		DATE:	
VERIFIED:		DATE:	

DRAWING No. 52-0002



REVISION DATES	

EROSION CONTROL LEGEND			
CREEK VIEW DRAINAGE IMPROVEMENTS			
CHECKED:		DATE:	
BACKCHECKED:		DATE:	
CORRECTED:		DATE:	
VERIFIED:		DATE:	

DRAWING No. 52-0002

CODE	PRACTICE STD OR DETAIL SPEC. SECT.	DETAIL	DESCRIPTION
Ch-2T1	TURF REINFORCEMENT MAT (TRM) CONSTRUCTION DETAIL D-35 SECTION 711		THIS THREE DIMENSIONAL EROSION CONTROL MAT IS USED IN CONJUNCTION WITH PERMANENT VEGETATION IN CHANNELS TO STABILIZE THE SOIL BY REINFORCING THE GRASS ROOTS TO PROVIDE LONG-TERM PROTECTION FOR SHEAR STRESSES 0-2 psf. THE TRM SHALL PROTECT THE CHANNEL FLOWING TO A DEPTH "Dp" RECOMMENDED BY THE GDOT CHANNEL LINING PROGRAM. *Dp* SHALL BE IDENTIFIED IN A TABLE LOCATED ON THE SUMMARY OF QUANTITIES SHEETS AND IN THE EROSION, SEDIMENTATION, AND POLLUTION CONTROL PLAN.
	LINE CODE		
Ch-2T2	TURF REINFORCEMENT MAT (TRM) CONSTRUCTION DETAIL D-35 SECTION 711		THIS THREE DIMENSIONAL EROSION CONTROL MAT IS USED IN CONJUNCTION WITH PERMANENT VEGETATION IN CHANNELS TO STABILIZE THE SOIL BY REINFORCING THE GRASS ROOTS TO PROVIDE LONG-TERM PROTECTION FOR SHEAR STRESSES 0-4 psf. THE TRM SHALL PROTECT THE CHANNEL FLOWING TO A DEPTH "Dp" RECOMMENDED BY THE GDOT CHANNEL LINING PROGRAM. *Dp* SHALL BE IDENTIFIED IN A TABLE LOCATED ON THE SUMMARY OF QUANTITIES SHEETS AND IN THE EROSION, SEDIMENTATION, AND POLLUTION CONTROL PLAN.
	LINE CODE		
Ch-2T3	TURF REINFORCEMENT MAT (TRM) CONSTRUCTION DETAIL D-35 SECTION 711		THIS THREE DIMENSIONAL EROSION CONTROL MAT IS USED IN CONJUNCTION WITH PERMANENT VEGETATION IN CHANNELS TO STABILIZE THE SOIL BY REINFORCING THE GRASS ROOTS TO PROVIDE LONG-TERM PROTECTION FOR SHEAR STRESSES 0-6 psf. THE TRM SHALL PROTECT THE CHANNEL FLOWING TO A DEPTH "Dp" RECOMMENDED BY THE GDOT CHANNEL LINING PROGRAM. *Dp* SHALL BE IDENTIFIED IN A TABLE LOCATED ON THE SUMMARY OF QUANTITIES SHEETS AND IN THE EROSION, SEDIMENTATION, AND POLLUTION CONTROL PLAN.
	LINE CODE		
Ch-2T4	TURF REINFORCEMENT MAT (TRM) CONSTRUCTION DETAIL D-35 SECTION 711		THIS THREE DIMENSIONAL EROSION CONTROL MAT IS USED IN CONJUNCTION WITH PERMANENT VEGETATION IN CHANNELS TO STABILIZE THE SOIL BY REINFORCING THE GRASS ROOTS TO PROVIDE LONG-TERM PROTECTION FOR SHEAR STRESSES 0-8 psf. THE TRM SHALL PROTECT THE CHANNEL FLOWING TO A DEPTH "Dp" RECOMMENDED BY THE GDOT CHANNEL LINING PROGRAM. *Dp* SHALL BE IDENTIFIED IN A TABLE LOCATED ON THE SUMMARY OF QUANTITIES SHEETS AND IN THE EROSION, SEDIMENTATION, AND POLLUTION CONTROL PLAN.
	LINE CODE		
Ch-2T5	TURF REINFORCEMENT MAT (TRM) CONSTRUCTION DETAIL D-35 SECTION 711		THIS THREE DIMENSIONAL EROSION CONTROL MAT IS USED IN CONJUNCTION WITH PERMANENT VEGETATION IN CHANNELS TO STABILIZE THE SOIL BY REINFORCING THE GRASS ROOTS TO PROVIDE LONG-TERM PROTECTION FOR SHEAR STRESSES 0-10 psf. THE TRM SHALL PROTECT THE CHANNEL FLOWING TO A DEPTH "Dp" RECOMMENDED BY THE GDOT CHANNEL LINING PROGRAM. *Dp* SHALL BE IDENTIFIED IN A TABLE LOCATED ON THE SUMMARY OF QUANTITIES SHEETS AND IN THE EROSION, SEDIMENTATION, AND POLLUTION CONTROL PLAN.
	LINE CODE		

CODE	PRACTICE STD OR DETAIL SPEC. SECT.	DETAIL	DESCRIPTION
Ch-2T6	TURF REINFORCEMENT MAT (TRM) CONSTRUCTION DETAIL D-35 SECTION 711		THIS THREE DIMENSIONAL EROSION CONTROL MAT IS USED IN CONJUNCTION WITH PERMANENT VEGETATION IN CHANNELS TO STABILIZE THE SOIL BY REINFORCING THE GRASS ROOTS TO PROVIDE LONG-TERM PROTECTION FOR SHEAR STRESSES 0-12 psf. THE TRM SHALL PROTECT THE CHANNEL FLOWING TO A DEPTH "Dp" RECOMMENDED BY THE GDOT CHANNEL LINING PROGRAM. *Dp* SHALL BE IDENTIFIED IN A TABLE LOCATED ON THE SUMMARY OF QUANTITIES SHEETS AND IN THE EROSION, SEDIMENTATION, AND POLLUTION CONTROL PLAN.
	LINE CODE		
Ch-3	CONCRETE CHANNEL STABILIZATION CONSTRUCTION DETAIL D-10, D-49 SECTION 441		CHANNELS ARE LINED WITH CONCRETE FOR VELOCITIES > 10 fps. THIS ITEM CONSISTS OF CONSTRUCTING A 4" THICK CONCRETE CHANNEL. THE CONCRETE SHALL PROTECT THE CHANNEL FLOWING TO A DEPTH "Dp" RECOMMENDED BY THE GDOT CHANNEL LINING PROGRAM. *Dp* SHALL BE IDENTIFIED IN A TABLE LOCATED ON THE SUMMARY OF QUANTITIES SHEETS AND IN THE EROSION, SEDIMENTATION, AND POLLUTION CONTROL PLAN. RIP-RAP SHOULD BE USED TO DISSIPATE ENERGY DOWNSTREAM OF CONCRETE LINED CHANNELS.
	LINE CODE		
Co	CONSTRUCTION EXIT CONSTRUCTION DETAIL D-41 SECTION 163,800		A CONSTRUCTION EXIT IS A STONE STABILIZED PAD THAT REDUCES OR ELIMINATES THE TRANSPORT OF MUD FROM CONSTRUCTION AREAS ONTO PUBLIC ROADS BY EQUIPMENT OR RUNOFF. BEST USED AT ACCESS POINTS, I.E. NEW LOCATION PROJECTS, BORROW PITS, WASTE PITS, ACCESS ROADS, ETC. SHOULD BE MINIMUM 20' WIDE, 50' LONG, 6" THICK, AND REQUIRES A GEOTEXTILE UNDERLAYER. ON SITES WHERE THE GRADE TOWARD A PAVED AREA IS GREATER THAN 2%, A FULL WIDTH DIVERSION RIDGE 6" TO 8" HIGH WITH 3:1 SLOPES SHALL BE CONSTRUCTED APPROXIMATELY 15' UPSTREAM OF PAVED AREA. A TIRE WASHING AREA TO REMOVE MUD MAY ALSO BE REQUIRED PRIOR TO ENTRANCE ONTO PUBLIC ROADWAYS. ALL CONSTRUCTION EXIT REQUIREMENTS ARE INCLUDED IN THE PRICE OF THE CONSTRUCTION EXIT.
	SYMBOL		
Dc-A	STREAM DIVERSION CHANNEL GEOTEXTILE, POLYETHYLENE FILM SECTION 163		A TEMPORARY CHANNEL CONSTRUCTED TO CONVEY FLOW AROUND A CONSTRUCTION SITE WHILE A PERMANENT DRAINAGE STRUCTURE IS BEING CONSTRUCTED IN A NATURAL STREAM. THIS IS A MEASURE USED TO PROTECT STREAM BEDS FROM EROSION. LINE THE CHANNEL WITH GEOTEXTILE OR POLYETHYLENE FILM. INSTALL TWO ROWS OF Sd1-S PARALLEL TO THE CHANNEL TO PREVENT SEDIMENT LADEN RUNOFF FROM ENTERING THE STREAM. THE SIZE OF THE CHANNEL WILL DEPEND ON THE DISCHARGE, CHANNEL GEOMETRY, CHANNEL SLOPE AND ROUGHNESS. IT IS ACCEPTABLE FOR VELOCITIES BETWEEN 0 - 2.5 fps. THE DRAINAGE AREA SHALL BE NOT GREATER THAN 1 SQUARE MILE. CONSTRUCTION OF THE DIVERSION CHANNEL IS INCLUDED IN THE COST OF THE STRUCTURE.
	LINE CODE		

- NOTE:
- DO NOT USE EROSION CONTROL ITEMS IN A FLOWING STREAM OR IN A TIDAL AREA BELOW HIGH TIDE.
 - FOR ADDITIONAL INFORMATION ON THE DESIGN AND APPLICATION OF EROSION AND SEDIMENT CONTROL BEST MANAGEMENT PRACTICES (BMPs), REFER TO THE LATEST EDITION OF THE GEORGIA SOIL AND WATER CONSERVATION COMMISSION'S, "MANUAL FOR EROSION AND SEDIMENT CONTROL IN GEORGIA".



NO SCALE

REVISION DATES	
3/2/2017	

EROSION CONTROL LEGEND			
UNIFORM CODE SHEET			
SHEET 3 OF 7			
CHECKED:	D. EARLETON	DATE:	01/01/16
BACKCHECKED:		DATE:	
CORRECTED:		DATE:	
VERIFIED:		DATE:	
			DRAWING No. 52-0003



REVISION DATES	

EROSION CONTROL LEGEND			
CREEK VIEW			
DRAINAGE IMPROVEMENTS			
CHECKED:		DATE:	
BACKCHECKED:		DATE:	
CORRECTED:		DATE:	
VERIFIED:		DATE:	
			DRAWING No. 52-0003

CODE	PRACTICE STD OR DETAIL SPEC. SECT.	DETAIL	DESCRIPTION
Dc-B	STREAM DIVERSION CHANNEL GEOTEXTILE ONLY SECTION 163		A TEMPORARY CHANNEL CONSTRUCTED TO CONVEY FLOW AROUND A CONSTRUCTION SITE WHILE A PERMANENT DRAINAGE STRUCTURE IS BEING CONSTRUCTED IN A NATURAL STREAM. THIS IS A MEASURE USED TO PROTECT STREAM BEDS FROM EROSION. LINE THE CHANNEL WITH GEOTEXTILE ONLY. INSTALL TWO ROWS OF Sd1-S PARALLEL TO THE CHANNEL TO PREVENT SEDIMENT LADEN RUNOFF FROM ENTERING THE STREAM. THE SIZE OF THE CHANNEL WILL DEPEND ON THE DISCHARGE, CHANNEL GEOMETRY, CHANNEL SLOPE AND ROUGHNESS. IT IS ACCEPTABLE FOR VELOCITIES BETWEEN 2.5 - 9.0 fps.
	LINE CODE 		THE DRAINAGE AREA SHALL BE NOT GREATER THAN 1 SQUARE MILE. CONSTRUCTION OF THE DIVERSION CHANNEL IS INCLUDED IN THE COST OF THE STRUCTURE.
Dc-C	STREAM DIVERSION CHANNEL RIP-RAP & GEOTEXTILE SECTION 163		A TEMPORARY CHANNEL CONSTRUCTED TO CONVEY FLOW AROUND A CONSTRUCTION SITE WHILE A PERMANENT DRAINAGE STRUCTURE IS BEING CONSTRUCTED IN A NATURAL STREAM. THIS IS A MEASURE USED TO PROTECT STREAM BEDS FROM EROSION. LINE THE CHANNEL WITH RIP-RAP AND GEOTEXTILE. INSTALL TWO ROWS OF Sd1-S PARALLEL TO THE CHANNEL TO PREVENT SEDIMENT LADEN RUNOFF FROM ENTERING THE STREAM. THE SIZE OF THE CHANNEL WILL DEPEND ON THE DISCHARGE, CHANNEL GEOMETRY, CHANNEL SLOPE AND ROUGHNESS. IT IS ACCEPTABLE FOR VELOCITIES BETWEEN 9.0 - 13.0 fps.
	LINE CODE 		THE DRAINAGE AREA SHALL BE NOT GREATER THAN 1 SQUARE MILE. CONSTRUCTION OF THE DIVERSION CHANNEL IS INCLUDED IN THE COST OF THE STRUCTURE.
DI-1	DIVERSION BERM CONSTRUCTION DETAIL D-47 SECTION 205		A NON-DESIGNED TEMPORARY EARTHEN BERM WITH A COMPACTED SUPPORTING RIDGE ON THE LOWER SIDE TO BE USED AT THE EDGE OF EMBANKMENT DURING THE GRADING OPERATION. THE BERMS ARE ALSO CONSTRUCTED ABOVE, ACROSS OR BELOW A SLOPE TO REDUCE THE LENGTH OF A SLOPE. THEY ARE USED TO INTERCEPT RUNOFF, PREVENTING SLOPE EROSION AND TO DIRECT THE RUNOFF TO A STABLE OUTLET, DOWN DRAINS "Dn1" OR CATCHMENT AREAS AND ON ALL GRADING PROJECTS.
	LINE CODE 		
DI-2	DIVERSION CHANNEL SECTION 205		A DESIGNED TEMPORARY OR PERMANENT CHANNEL WITH A COMPACTED SUPPORTING RIDGE ON THE LOWER SIDE TO DIVERT OFFSITE RUNOFF AWAY FROM DISTURBED AREAS WITHIN THE PROJECT AREA. CHANNEL FOR OFFSITE RUNOFF SHALL BE STABILIZED WITH APPROPRIATE CHANNEL STABILIZATION. REFER TO THE LATEST EDITION OF THE "MANUAL FOR EROSION AND SEDIMENT CONTROL IN GEORGIA" FOR DESIGN CRITERIA. A DIVERSION CHANNEL DETAIL MUST ALSO BE PROVIDED IN THE ESPPC.
	LINE CODE 		RUNOFF FROM DISTURBED AREAS WITHIN THE PROJECT AREA SHALL NOT BE ALLOWED TO CONVERGE WITH OFFSITE RUNOFF WITHIN THIS DIVERSION.
Dn1	TEMPORARY DOWNDRAIN STRUCTURE FLEXIBLE CONSTRUCTION DETAIL D-19 SECTION 163		A TEMPORARY PIPE SLOPE DRAIN IS A PLASTIC FLEXIBLE PIPE TO CARRY WATER FROM THE WORK AREA TO A LOWER ELEVATION. TEMPORARY SLOPE DRAINS SHOULD BE PLACED AT INTERVALS OF 350 FEET ON 0% - 2% GRADES, 200 FEET ON STEEPER GRADES AND MORE FREQUENTLY AS DICTATED BY FIELD CONDITIONS. THE TYPICAL PIPE SIZE IS A CORRUGATED 10". THE PIPE WILL BE ANCHORED WITH STAKES AT INTERVALS NOT TO EXCEED 10".
	LINE CODE 		THE OUTLET AREA SHALL BE STABILIZED FOR VELOCITY DISSIPATION AND EROSION CONTROL.

CODE	PRACTICE STD OR DETAIL SPEC. SECT.	DETAIL	DESCRIPTION
Dn2-A	PERMANENT DOWNDRAIN STRUCTURE CONCRETE CONSTRUCTION DETAIL D-9 SECTION 441		A CONCRETE FLUME TYPE "A" IS USED TO DIRECT SURFACE RUNOFF DOWN A ROADWAY SLOPE INTO ANOTHER FORM OF CONTROL. IT IS USED IN ALL DEPRESSED AREAS WHERE WATER WILL FLOW DOWN THE SLOPE. IT IS DESIGNED FOR A 25-YEAR STORM AND MUST HAVE SOME FORM OF OUTLET PROTECTION. ADDITIONAL LABELING IS NOT REQUIRED IF SHOWN AS A PERMANENT DRAINAGE STRUCTURE ON THE CONSTRUCTION PLANS. INLETS SHALL BE SPACED ACCORDING TO GDOT GUIDELINES (REGARDING GUTTER SPREAD AND OTHER CRITERIA).
	LINE CODE 		
Dn2-B	PERMANENT DOWNDRAIN STRUCTURE CONCRETE CONSTRUCTION DETAIL D-9 SECTION 441		A CONCRETE FLUME TYPE "B" IS USED TO DIRECT SURFACE DITCH RUNOFF DOWN A BACK SLOPE INTO ANOTHER FORM OF CONTROL. IT IS USED IN DEPRESSED AREAS WHERE CONCENTRATED OFFSITE WATER REACHES THE CUT SLOPE. IT IS DESIGNED TO SAFELY CONVEY WATER DOWN THE CUT SLOPE. IT IS DESIGNED FOR A 25-YEAR STORM AND MUST HAVE SOME FORM OF OUTLET PROTECTION. ADDITIONAL LABELING IS NOT REQUIRED IF SHOWN AS A PERMANENT DRAINAGE STRUCTURE ON THE CONSTRUCTION PLANS. INLETS SHALL BE SPACED ACCORDING TO GDOT GUIDELINES (REGARDING GUTTER SPREAD AND OR OTHER CRITERIA).
	LINE CODE 		
Dn2-1	PERMANENT DOWNDRAIN STRUCTURE GA. STD 9013 TP1, 9017J TP1, DETAIL D-26 TP1 SECTION 576, 577		CONCRETE DRAIN INLET WITH METAL PIPE IS USED TO DRAIN CURBS, ON A GRADE, DOWN TO A LOWER ELEVATION. THIS IS A PERMANENT STRUCTURE, REQUIRING OUTLET PROTECTION, TEMPORARY AND PERMANENT. INLETS SHALL BE SPACED ACCORDING TO GDOT GUIDELINES (REGARDING GUTTER SPREAD AND OR OTHER CRITERIA).
	LINE CODE 		
Dn2-2	PERMANENT DOWNDRAIN STRUCTURE GA. STD 9013 TP2, 9017J TP2, DETAIL D-26 TP2 SECTION 576, 577		CONCRETE DRAIN INLET AND METAL PIPE IS USED TO DRAIN CURB, IN A SAG, DOWN TO A LOWER ELEVATION. THIS IS A PERMANENT STRUCTURE, REQUIRING OUTLET PROTECTION, TEMPORARY AND PERMANENT. INLETS SHALL BE SPACED ACCORDING TO GDOT GUIDELINES (REGARDING GUTTER SPREAD AND OR OTHER CRITERIA).
	LINE CODE 		

NOTE:

- DO NOT USE EROSION CONTROL ITEMS IN A FLOWING STREAM OR IN A TIDAL AREA BELOW HIGH TIDE.
- FOR ADDITIONAL INFORMATION ON THE DESIGN AND APPLICATION OF EROSION AND SEDIMENT CONTROL BEST MANAGEMENT PRACTICES (BMPs), REFER TO THE LATEST EDITION OF THE GEORGIA SOIL AND WATER CONSERVATION COMMISSION'S, "MANUAL FOR EROSION AND SEDIMENT CONTROL IN GEORGIA".



NO SCALE

REVISION DATES	
3/2/2017	

EROSION CONTROL LEGEND
UNIFORM CODE SHEET
SHEET 4 OF 7

CHECKED: D. EARLETON	DATE: 01/01/16	DRAWING No.
BACKCHECKED:	DATE:	
CORRECTED:	DATE:	
VERIFIED:	DATE:	52-0004



REVISION DATES

EROSION CONTROL LEGEND
CREEK VIEW
DRAINAGE IMPROVEMENTS

CHECKED:	DATE:	DRAWING No.
BACKCHECKED:	DATE:	
CORRECTED:	DATE:	
VERIFIED:	DATE:	52-0004

CODE	PRACTICE STD OR DETAIL SPEC. SECT.	DETAIL	DESCRIPTION
Fr	FILTER RING		A TEMPORARY STONE BARRIER CONSTRUCTED AT DRAINAGE STRUCTURE INLETS AND POST-CONSTRUCTION POND OUTLETS. IT REDUCES RUNOFF VELOCITY AND HELPS PREVENT SEDIMENT FROM LEAVING SITE PRIOR TO PERMANENT STABILIZATION OF THE DISTURBED AREA.
	CONSTRUCTION DETAIL D-46 SECTION 163	SYMBOL 	REFER TO THE LATEST EDITION OF THE "MANUAL FOR EROSION AND SEDIMENT CONTROL IN GEORGIA" FOR ADDITIONAL INFORMATION ON USAGE.
Rd	ROCK FILTER DAM		ROCK FILTER DAMS ARE CONSTRUCTED OF TYPE 3 STONE RIP-RAP FACED WITH #57 STONE ON THE UPSTREAM SIDE. THEY ARE PLACED ACROSS DRAINAGEWAYS WHICH DRAIN 50 ACRES OR LESS. GEOTEXTILE UNDERLINER SHALL BE USED WHEN PLACING ROCK FILTER DAMS.
	CONSTRUCTION DETAIL D-43 SECTION 163, 603	SYMBOL 	THE DAM SHOULD NOT BE HIGHER THAN THE CHANNEL BANKS. ROCK FILTER DAMS SHOULD BE USED IN DITCHES PRIOR TO DISCHARGING INTO STREAMS, WETLANDS, OPEN-WATERS, OR OTHER ESAs.
Rd-B	STONE FILTER BERM		STONE FILTER BERMS ARE CONSTRUCTED SIMILAR TO ROCK FILTER DAMS FOR A LINEAR APPLICATION. THEY ARE CONSTRUCTED OF TYPE-3 STONE RIP-RAP FACED WITH #57 STONE ON THE UPSTREAM SIDE. GEOTEXTILE UNDERLINER SHALL BE USED WHEN PLACING STONE FILTER BERMS.
	CONSTRUCTION DETAIL D-50 SECTION 163, 603	LINE CODE 	STONE FILTER BERMS ARE IDEAL ALONG THE PERIMETER FOR SHEET FLOW AND/OR SHALLOW CONCENTRATED FLOW TO A COMMON LOW AREA WHERE PERIMETER SILT FENCE ALONE MAY BE INSUFFICIENT. THERE IS NO WELL-DEFINED CHANNEL FOR A STANDARD ROCK FILTER DAM. AND/OR CONSTRUCTING A ROCK OUTLET TEMPORARY SEDIMENT TRAP IS NOT APPLICABLE.
Rp	RIP-RAP		RIP-RAP IS A FLEXIBLE PERMANENT BLANKET FOR PROTECTION OF FILL SLOPES AND BRIDGE END ROLLS. RIP-RAP TYPE-1 SHOULD BE PLACED ON TOP OF A GEOTEXTILE UNDERLINER AT A MINIMUM 24" THICKNESS OR AS INDICATED ON THE PLANS.
	SECTION 603	PATTERN 	RIP-RAP MAY ALSO BE USED AT DRAINAGE STRUCTURE OUTLETS WITHIN THE RIGHT-OF-WAY. HOWEVER, APPROPRIATE OUTLET PROTECTION SHOULD BE PROVIDED AT OUTFALLS. REFER TO STORM DRAIN OUTLET PROTECTION FOR ADDITIONAL INFORMATION ON USING RIP-RAP AT OUTFALLS.
Rt-P	RETROFITTING PERFORATED HALF-ROUND PIPE		A PERFORATED HALF-ROUND PIPE WITH STONE FILTER PLACED IN FRONT OF A PERMANENT STORMWATER DETENTION POND OUTLET STRUCTURE TO SERVE AS A TEMPORARY SEDIMENT FILTER.
	CONSTRUCTION DETAIL D-44 SECTION 163	SYMBOL 	SHOULD BE USED ONLY IN DETENTION PONDS WITH LESS THAN 30 ACRES TOTAL DRAINAGE AREA. SHALL ONLY BE USED IN DETENTION BASINS LARGE ENOUGH TO STORE 67 CUBIC YARDS OF SEDIMENT PER ACRE OF DISTURBED AREA. REFER TO THE LATEST EDITION OF THE "MANUAL FOR EROSION AND SEDIMENT CONTROL IN GEORGIA" FOR DESIGN CRITERIA.

CODE	PRACTICE STD OR DETAIL SPEC. SECT.	DETAIL	DESCRIPTION
Rt-B	RETROFITTING SLOTTED BOARD DAM		A SLOTTED BOARD DAM CONSISTS OF STONE AND/OR FILTER FABRIC AND BOARDS WITH 0.5" - 1.0" SPACING TO SERVE AS A TEMPORARY SEDIMENT FILTER.
	CONSTRUCTION DETAIL D-45 SECTION 163	SYMBOL 	PERMANENT STORMWATER DETENTION POND OUTLET: -DRAINAGE AREA UP TO 100 ACRES -DETENTION BASINS LARGE ENOUGH TO STORE 67 CUBIC YARDS OF SEDIMENT PER ACRE OF DISTURBED AREA ROADWAY DRAINAGE STRUCTURE: -OPEN END PIPES, WINGED HEADWALLS, OR CONCRETE WEIR OUTLETS WITH DRAINAGE AREA LESS THAN 30 ACRES REFER TO THE LATEST EDITION OF THE "MANUAL FOR EROSION AND SEDIMENT CONTROL IN GEORGIA" FOR DESIGN CRITERIA.
Rt-Sg1 Rt-Sg2 Rt-Sg3	RETROFITTING SILT CONTROL GATES		A SILT CONTROL GATE CONSISTS OF BOARDS WITHOUT SPACING AND FILTER FABRIC TO BE USED FOR TEMPORARY SEDIMENT STORAGE ON ROADWAY PROJECTS AT THE INLET OF STRUCTURES WITH A DRAINAGE AREA UP TO 50 ACRES. THE DISTURBED AREA WITHIN THE DRAINAGE AREA SHALL NOT EXCEED 5 ACRES. SILT CONTROL GATES SHOULD NOT BE USED ALONE, BUT WITH ANOTHER BMP DOWNSTREAM PRIOR TO DISCHARGE LEAVING PROJECT AREA.
	CONSTRUCTION DETAIL D-20 SECTION 163	FRONT VIEW 	DO NOT USE SILT GATES IN STATE WATERS.
	SYMBOL 	Rt-Sg1-TYPE 1: USED ON BOX CULVERTS Rt-Sg2-TYPE 2: USED ON STRAIGHT HEADWALLS Rt-Sg3-TYPE 3: USED ON FLARED END SECTIONS AND TAPERED HEADWALLS	
SdI-NS	SEDIMENT BARRIER (NON-SENSITIVE) SILT FENCE TYPE A		SEDIMENT BARRIERS MINIMIZE AND PREVENT SEDIMENT CARRIED BY SHEET FLOW FROM LEAVING THE PROJECT AREA BY CAUSING DEPOSITION AND/OR FILTRATION OF SEDIMENT. SILT FENCE USED AS PERIMETER CONTROL SHALL NOT BE INSTALLED ACROSS CONCENTRATED FLOW.
	CONSTRUCTION DETAIL D-24 SECTION 171	LINE CODE 	TYPE-A SILT FENCE IS TYPICALLY USED IN NON-ENVIRONMENTALLY SENSITIVE AREAS (ESAs) OR IN AREAS WITH FILLS LESS THAN 10'. IT SHOULD BE PLACED A MINIMUM OF 10' FROM CONSTRUCTION LIMITS OR ALONG THE RIGHT-OF-WAY LINE.
SdI-S	SEDIMENT BARRIER (SENSITIVE) SILT FENCE TYPE C		SEDIMENT BARRIERS MINIMIZE AND PREVENT SEDIMENT CARRIED BY SHEET FLOW FROM LEAVING THE PROJECT AREA BY CAUSING DEPOSITION AND/OR FILTRATION OF SEDIMENT. SILT FENCE USED AS PERIMETER CONTROL SHALL NOT BE INSTALLED ACROSS CONCENTRATED FLOW.
	CONSTRUCTION DETAIL D-24 SECTION 171	LINE CODE 	TYPE-C SILT FENCE IS TYPICALLY USED IN ENVIRONMENTALLY SENSITIVE AREAS (ESAs) OR IN AREAS WITH FILLS 10' AND GREATER. ALL ENVIRONMENTALLY SENSITIVE AREAS (ESAs) SHALL BE PROTECTED WITH A DOUBLE-ROW OF TYPE-C SILT FENCE REGARDLESS OF FILL HEIGHT. A SINGLE-ROW MAY BE USED FOR OTHER APPLICATIONS. IT SHOULD BE PLACED A MINIMUM OF 10' FROM CONSTRUCTION LIMITS OR ALONG THE RIGHT-OF-WAY LINE.

NOTE:

- DO NOT USE EROSION CONTROL ITEMS IN A FLOWING STREAM OR IN A TIDAL AREA BELOW HIGH TIDE.
- FOR ADDITIONAL INFORMATION ON THE DESIGN AND APPLICATION OF EROSION AND SEDIMENT CONTROL BEST MANAGEMENT PRACTICES (BMPs), REFER TO THE LATEST EDITION OF THE GEORGIA SOIL AND WATER CONSERVATION COMMISSION'S, "MANUAL FOR EROSION AND SEDIMENT CONTROL IN GEORGIA".



NO SCALE

REVISION DATES	
3/2/2017	

EROSION CONTROL LEGEND
UNIFORM CODE SHEET
SHEET 5 OF 7

CHECKED:	G. EARLETH	DATE:	01/01/16	DRAWING No.
BACKCHECKED:		DATE:		
CORRECTED:		DATE:		
VERIFIED:		DATE:		

52-0005









REVISION DATES

EROSION CONTROL LEGEND
CREEK VIEW
DRAINAGE IMPROVEMENTS

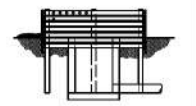
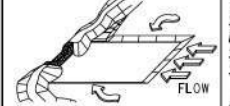
CHECKED:		DATE:		DRAWING No.
BACKCHECKED:		DATE:		
CORRECTED:		DATE:		
VERIFIED:		DATE:		

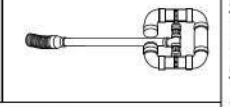
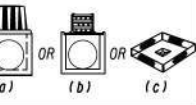
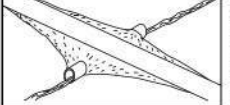
52-0005

11/28/2018 dreg1110		10:54:38 AM gploborder-VBI-PO.tbl		GPLOT-V8 gploborder-VBI-PO.tbl		EC-C:\sheds\1-71.dgn		P. I. No.	
				GD&T					
CODE	PRACTICE STD OR DETAIL SPEC. SECT.	DETAIL	DESCRIPTION	CODE	PRACTICE STD OR DETAIL SPEC. SECT.	DETAIL	DESCRIPTION		
Sd1-BB	SEDIMENT BARRIER BRUSH BARRIER CONSTRUCTION DETAIL D-24B SECTION 201		THIS ITEM CONSISTS OF INTERMINGLED BRUSH, LOGS, ETC. SO AS NOT TO FORM A SOLID DAM. CONSTRUCTED AT THE TOE OF FILL SLOPES ONLY DURING THE CLEARING AND GRUBBING OPERATION. THE BARRIER SHOULD BE USED AT THE TOE OF FILL SLOPES ON GRADING PROJECTS IN RURAL AREAS WHERE SUFFICIENT RIGHT OF WAY OR EASEMENT IS AVAILABLE (10 FEET OR MORE). THE BARRIER SHOULD RUN ROUGHLY PERPENDICULAR TO THE FLOW OF WATER WHERE THIS DOES NOT CONFLICT WITH RIGHT-OF-WAY OR EASEMENT LIMITS. THEY WILL NOT BE PLACED IN WETLANDS.	Sd3	TEMPORARY SEDIMENT BASIN CONSTRUCTION DETAIL D-22A, D-22B SECTION 163		A BASIN CREATED BY EXCAVATING AN AREA, DAMMING CONCENTRATED FLOW, OR A COMBINATION OF BOTH. THE BASIN IS DESIGNED TO STORE 67 CUBIC YARDS OF SEDIMENT PER ACRE OF DRAINAGE AREA. THE DRAINAGE AREA SHOULD NOT EXCEED 150 ACRES. BASINS TYPICALLY CONSISTS OF A DAM, PRINCIPAL SPILLWAY, AND AN EMERGENCY SPILLWAY. A FLOATING SURFACE SKIMMER SHALL BE REQUIRED AS PART OF THE PRINCIPAL SPILLWAY UNLESS INFEASIBLE. SUFFICIENT RIGHT-OF-WAY OR EASEMENT IS NEEDED FOR BASIN CONSTRUCTION AND MAINTENANCE ACCESS.		
	LINE CODE * * * Sd1-BB * * *		TYPICALLY NOT SHOWN ON PLANS. PAYMENT FOR THIS ITEM IS INCLUDED IN THE CLEARING AND GRUBBING COST. NO SEPARATE PAYMENT SHALL BE MADE.		SYMBOL Sd3		SEDIMENT BASINS SHALL BE CONSIDERED ON ALL PROJECTS, BUT MAY NOT BE PRACTICAL. BASINS SHOULD BE LOCATED TO MINIMIZE INTERFERENCE WITH CONSTRUCTION ACTIVITIES AND UTILITIES. REFER TO THE LATEST EDITION OF THE "MANUAL FOR EROSION AND SEDIMENT CONTROL IN GEORGIA" FOR DESIGN CRITERIA.		
Sd2-B	INLET SEDIMENT TRAP (BAFFLE BOX) CONSTRUCTION DETAIL D-42 SECTION 163		BAFFLE BOX INLET SEDIMENT TRAP USED FOR INLETS RECEIVING HIGH FLOW RATE AND/OR VELOCITY. A GUIDE FOR USE WILL BE FOR AN INLET RECEIVING FLOW RATES 7 cfs AND GREATER.	Sd4-C	ROCK OUTLET TEMPORARY SEDIMENT TRAP CONSTRUCTION DETAIL D-53 SECTION 163		TEMPORARY POND WITH ROCK OUTLET DESIGNED TO STORE 67 CUBIC YARDS OF SEDIMENT PER DRAINAGE AREA. DRAINAGE AREA SHALL NOT EXCEED 5 ACRES. DISTINGUISHED FROM TEMPORARY SEDIMENT BASIN BY LACK OF PRINCIPAL SPILLWAY. MAXIMUM POND DEPTH FROM BOTTOM OF POND TO EMERGENCY SPILLWAY IS 4 FEET.		
	SYMBOL Sd2-B				SYMBOL Sd4-C		A TEMPORARY SEDIMENT BASIN SHALL BE EVALUATED PRIOR TO CONSIDERING A TEMPORARY SEDIMENT TRAP. A TEMPORARY SEDIMENT TRAP IS IDEAL FOR SMALL AREAS WITH NO UNUSUAL DRAINAGE FEATURES AND EFFECTIVE AGAINST COARSE SEDIMENT, BUT NOT AGAINST SILT OR CLAY PARTICLES THAT REMAIN SUSPENDED. REFER TO THE LATEST EDITION OF THE "MANUAL FOR EROSION AND SEDIMENT CONTROL IN GEORGIA" FOR DESIGN CRITERIA.		
Sd2-Bg	INLET SEDIMENT TRAP (BLOCK & GRAVEL) CONSTRUCTION DETAIL D-42 SECTION 163		BLOCK AND GRAVEL DROP INLET PROTECTION USED FOR WHERE HEAVY FLOWS ARE EXPECTED AND WHERE OVERFLOW CAPACITY IS NECESSARY TO PREVENT EXCESSIVE PONDING AROUND THE STRUCTURE. CAN BE USED AT CULVERT INLETS. A GUIDE FOR USE WILL BE FOR AN INLET RECEIVING FLOW RATES THAT RANGE FROM 5 - 7 cfs.	Sk	FLOATING SURFACE SKIMMER CONSTRUCTION DETAIL D-22A, D-22B SECTION 163		A BUOYANT DEVICE THAT DRAINS WATER FROM THE SURFACE OF A TEMPORARY SEDIMENT BASIN AT A CONTROLLED FLOW RATE. THE INLET/DRIFICE SIZE IS DESIGNED TO DRAIN THE BASIN WITHIN 24 - 48 HOURS. THE SKIMMER INFORMATION SHALL BE PROVIDED IN CONJUNCTION WITH THE SEDIMENT BASIN INFORMATION IN PLANS. IF A SKIMMER IS INFEASIBLE, THE DESIGNER SHALL PROVIDE A WRITTEN JUSTIFICATION IN THE PLANS.		
	SYMBOL Sd2-Bg				SYMBOL Sk		SKIMMERS ARE ATTACHED TO A RISER WITHOUT PERFORATIONS AND ACTS AS THE PRIMARY SPILLWAY. THE SKIMMER BMP SYMBOL SHALL BE SHOWN IN CONJUNCTION WITH THE TEMPORARY SEDIMENT BASIN BMP SYMBOL WHEN APPLICABLE. REFER TO THE LATEST EDITION OF THE "MANUAL FOR EROSION AND SEDIMENT CONTROL IN GEORGIA" FOR ADDITIONAL INFORMATION.		
Sd2-F	INLET SEDIMENT TRAP (FILTER FABRIC) CONSTRUCTION DETAIL D-24C SECTION 163		(a) A SEDIMENT BARRIER CONSISTING OF A PREFABRICATED FRAME WITH FILTER FABRIC USED AROUND A DROP INLET OR CATCH BASIN. (b) A SEDIMENT BARRIER CONSISTING OF A PERFORATED METAL STAND PIPE WITH FILTER FABRIC USED AROUND A DROP INLET OR CATCH BASIN. (c) TYPE C SILT FENCE WITH SUPPORTING FRAME CAN BE USED AS AN ALTERNATE TO INLET SEDIMENT TRAP FOR AREAS WITH SLOPES < 5%.	Sr	TEMPORARY STREAM CROSSING SECTION 107		A TEMPORARY STRUCTURE INSTALLED ACROSS A FLOWING STREAM OR WATERCOURSE FOR USE BY CONSTRUCTION EQUIPMENT. THIS BMP PROVIDES A MEANS TO CROSS STREAMS OR WATERCOURSES WITHOUT MOVING SEDIMENT INTO STREAMS, DAMAGING THE STREAM BED OR CHANNEL, OR CAUSING FLOODING. THIS BMP SHOULD NOT BE USED ON STREAMS WITH DRAINAGE AREAS GREATER THAN ONE SQUARE MILE, UNLESS SPECIFICALLY DESIGNED TO ACCOMMODATE THE ADDITIONAL DRAINAGE AREA BY THE DESIGN PROFESSIONAL. A CERTIFICATION STATEMENT AND SIGNATURE SHALL ACCOMPANY THE DESIGN.		
	SYMBOL Sd2-F		THIS ITEM IS USED TO PREVENT SILT FROM ENTERING THE PIPE SYSTEM. SHALL NOT APPLY TO INLETS RECEIVING CONCENTRATED FLOWS. RECOMMENDED FOR INLET RECEIVING FLOW RATES THAT RANGE FROM 0 - 4 cfs.		SYMBOL Sr		THIS BMP SHALL BE DESIGNED ACCORDING TO THE LATEST EDITION OF THE "MANUAL FOR EROSION AND SEDIMENT CONTROL IN GEORGIA". FOR CONTRACTOR'S USE ONLY!		
Sd2-G	INLET SEDIMENT TRAP (GRAVEL) CONSTRUCTION DETAIL D42 SECTION 163		GRAVEL DROP INLET PROTECTION USED WHERE HEAVY CONCENTRATED FLOWS ARE EXPECTED. STONE AND GRAVEL ARE USED TO TRAP SEDIMENT. THE SLOPE TOWARD THE INLET SHALL BE NO MORE THAN 3:1. A GUIDE FOR USE WILL BE FOR AN INLET RECEIVING FLOW RATES THAT RANGE FROM 3 - 5 cfs.						
	SYMBOL Sd2-G								

NOTE:

- DO NOT USE EROSION CONTROL ITEMS IN A FLOWING STREAM OR IN A TIDAL AREA BELOW HIGH TIDE.
- FOR ADDITIONAL INFORMATION ON THE DESIGN AND APPLICATION OF EROSION AND SEDIMENT CONTROL BEST MANAGEMENT PRACTICES (BMPs), REFER TO THE LATEST EDITION OF THE GEORGIA SOIL AND WATER CONSERVATION COMMISSION'S, "MANUAL FOR EROSION AND SEDIMENT CONTROL IN GEORGIA".



NO SCALE

REVISION DATES		EROSION CONTROL LEGEND	
3/2/2017		UNIFORM CODE SHEET SHEET 6 OF 7	
11/28/2018			
		CHECKED: D. EBLETON	DATE: 01/01/18
		BACKCHECKED:	DATE:
		CORRECTED:	DATE:
		VERIFIED:	DATE:
		DRAWING No. 52-0006	



REVISION DATES		EROSION CONTROL LEGEND	
		CREEK VIEW DRAINAGE IMPROVEMENTS	
		CHECKED:	DATE:
		BACKCHECKED:	DATE:
		CORRECTED:	DATE:
		VERIFIED:	DATE:
		DRAWING No. 52-0006	

CODE	PRACTICE STD OR DETAIL SPEC. SECT.	DETAIL	DESCRIPTION
St	STORM DRAIN OUTLET PROTECTION GA. STD. 1125 & 2332		A PIPE OR BOX CULVERT OUTLET HEADWALL WITH AN APRON AND DISSIPATOR BLOCKS IS USED TO REDUCE VELOCITY AT THE OUTLET OF A PIPE PRIOR TO ENTERING AN EXISTING STREAM OR PUBLICLY MAINTAINED DRAINAGE SYSTEM. IT IS USED ON THE OUTLET OF ALL BOX CULVERTS AND ON 48" AND LARGER PIPES. MAY BE USED ON INLET FOR FLOWING STREAMS. USE ON SMALL PIPES WHEN OUTLET VELOCITY OF THE 25-YEAR STORM IS 12 fps AND GREATER.
	SYMBOL 		
St-Rp	STORM DRAIN OUTLET PROTECTION (RIP-RAP) CONSTRUCTION DETAIL D-55 SECTION 603		RIP-RAP OUTLET PROTECTION IS USED TO REDUCE VELOCITY AT THE OUTLET OF A PIPE, CHANNEL, OR STRUCTURE PRIOR TO ENTERING AN EXISTING STREAM OR PUBLICLY MAINTAINED DRAINAGE SYSTEM. THE MINIMUM DESIGN OF RIP-RAP OUTLET PROTECTION SHALL BE THE 25-YEAR STORM PEAK FLOW, BUT LARGER STORMS ARE RECOMMENDED. TYPE-1 RIP-RAP AT A DEPTH OF 36" AND PLACED ON FILTER FABRIC IS PREFERRED FOR ALL d50 ≤ 1.2 FEET. TYPE-3 RIP-RAP AT A DEPTH OF 18" AND PLACED ON FILTER FABRIC MAY BE USED FOR d50 ≤ 0.7 FEET.
	PATTERN 		REFER TO THE LATEST EDITION OF THE "MANUAL FOR EROSION AND SEDIMENT CONTROL IN GEORGIA" FOR REQUIRED DESIGN DIMENSIONS AND OTHER INFORMATION TO BE INCLUDED IN THE PLANS.
Su	SURFACE ROUGHENING SERRATED SLOPES CONSTRUCTION DETAIL S-7 SECTION 205		PROVIDING A ROUGH SOIL SURFACE WITH HORIZONTAL DEPRESSIONS, BY OPERATING A CLEATED DOZER ON THE SLOPE IN A VERTICAL DIRECTION. CREATING SERRATED SLOPES IN THE GRADING PROCESS TO CONSTRUCT BENCHES WILL REDUCE RUNOFF VELOCITY AND INCREASE INFILTRATION OF WATER. IN MOST CASES THIS BMP IS NOT REQUIRED TO BE SHOWN ON THE PLANS, BUT REQUIRED TO BE COMPLETED BY THE CONTRACTOR UNDER ALL PROJECTS. IF SERRATED SLOPES ARE SPECIFIED BY THE SOIL SURVEY, THEN THIS BMP SHALL BE SHOWN ON THE PLANS WHERE SERRATED SLOPES ARE TO BE USED.
	LINE CODE 		
Tc-F	TURBIDITY CURTAIN FLOATING CONSTRUCTION DETAIL D-51 SECTION 170		A FLOATING TURBIDITY CURTAIN IS USED TO PREVENT SEDIMENT FROM MOVING IN WATER BY ALLOWING IT TO DROP OUT OF SUSPENSION AND REMAIN WITHIN THE CONSTRUCTION AREA. IT IS TYPICALLY USED WHERE CONSTRUCTION IS REQUIRED IN A LARGE BODY OF WATER SUCH AS LAKES AND RIVERS. IT SHOULD BE USED AS DIRECTED BY THE ENGINEER. THIS BMP IS ONLY TO BE USED WHEN PERMITTED FILL IS BEING PLACED INTO A STATE WATER, OR AS A SUPPLEMENT TO ADEQUATELY PLACED PERIMETER BMPs. IT MAY ALSO BE REFERRED TO AS A FLOATING BOOM, SILT BARRIER, OR SILT CURTAIN.
	LINE CODE 		
Tc-S	TURBIDITY CURTAIN STAKED CONSTRUCTION DETAIL D-51 SECTION 170		A STAKED TURBIDITY CURTAIN IS USED TO PREVENT SEDIMENT FROM MOVING IN WATER BY ALLOWING IT TO DROP OUT OF SUSPENSION AND REMAIN WITHIN THE CONSTRUCTION AREA. IT IS TYPICALLY USED IN SHALLOW INUNDATED AREAS. IT MAY BE USED TO PROTECT A SMALL STREAM BEING REALIGNED OR RESTORED. IN THIS CASE, CURTAIN SHOULD EXTEND TO BOTTOM OF STREAMBED. THE HEIGHT SHOULD BE LIMITED TO 5 FEET UNLESS DIRECTED AND EXTEND 2 FEET ABOVE NORMAL WATER ELEVATION. IT SHOULD BE USED AS DIRECTED BY THE ENGINEER. THIS BMP IS ONLY TO BE USED WHEN PERMITTED FILL IS BEING PLACED INTO A STATE WATER, OR AS A SUPPLEMENT TO ADEQUATELY PLACED PERIMETER BMPs. IT MAY BE REFERRED TO AS A SILT BARRIER OR SILT CURTAIN.
	LINE CODE 		

NO SCALE

REVISION DATES	
3/2/2017	

EROSION CONTROL LEGEND
UNIFORM CODE SHEET
SHEET 7 OF 7

CHECKED: D. ENGLETON	DATE: 01/01/16	DRAWING No.
BACKCHECKED:	DATE:	
CORRECTED:	DATE:	
VERIFIED:	DATE:	

52-0007

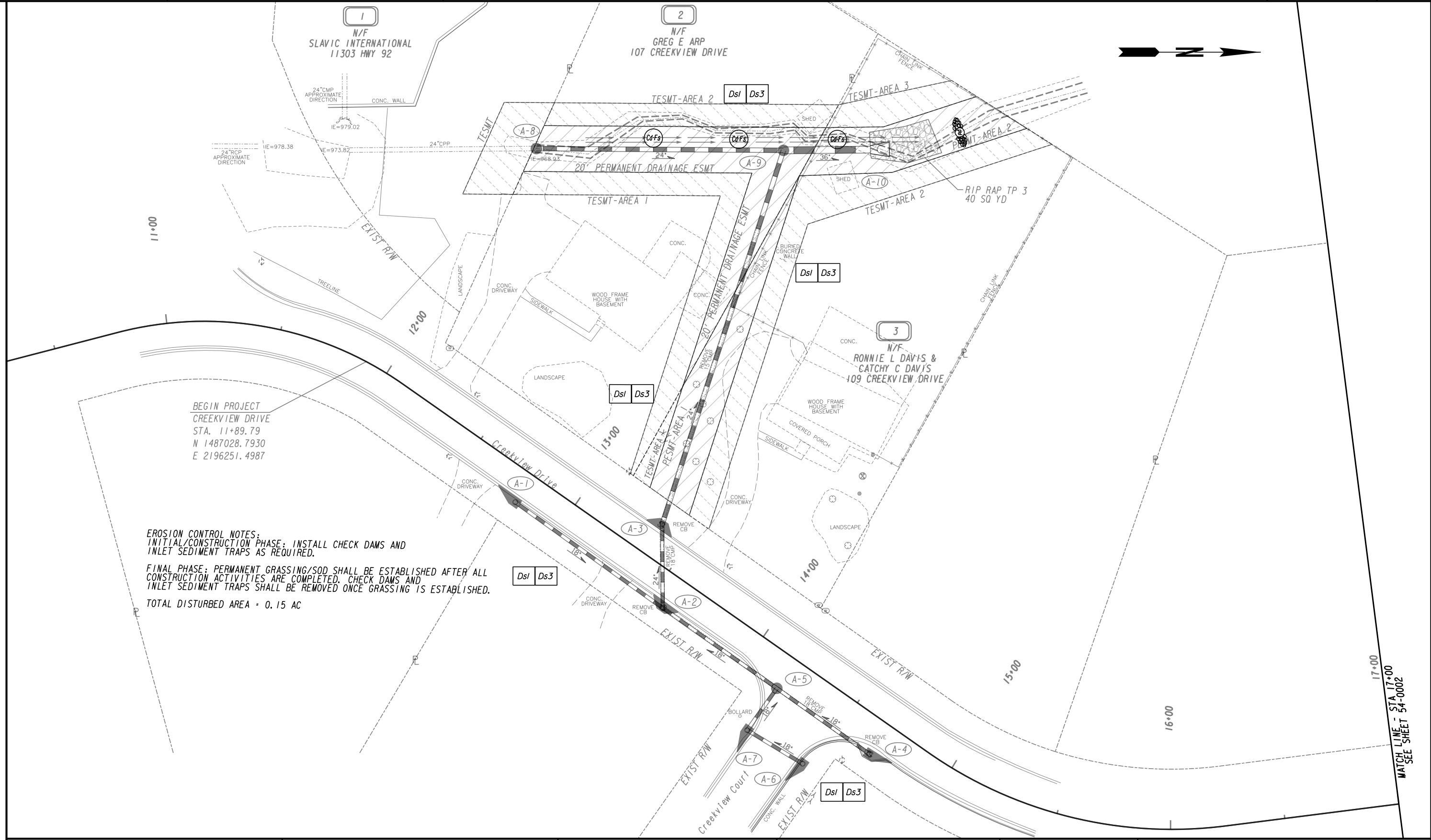

BEGIN PROJECT
CREEKVIEW DRIVE
STA. 11+89.79
N 1487028.7930
E 2196251.4987

EROSION CONTROL NOTES:
 INITIAL/CONSTRUCTION PHASE: INSTALL CHECK DAMS AND INLET SEDIMENT TRAPS AS REQUIRED.
 FINAL PHASE: PERMANENT GRASSING/SOD SHALL BE ESTABLISHED AFTER ALL CONSTRUCTION ACTIVITIES ARE COMPLETED. CHECK DAMS AND INLET SEDIMENT TRAPS SHALL BE REMOVED ONCE GRASSING IS ESTABLISHED.
 TOTAL DISTURBED AREA = 0.15 AC

17+00
WATCH LINE - STA 17+00
SEE SHEET 54-0002

PROPERTY AND EXISTING R/W LINE
 REQUIRED R/W LINE
 CONSTRUCTION LIMITS
 EASEMENT FOR CONSTR
 & MAINTENANCE OF SLOPES
 EASEMENT FOR CONSTR OF SLOPES
 EASEMENT FOR CONSTR OF DRIVES

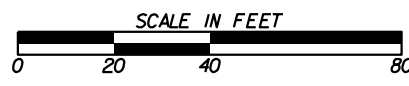
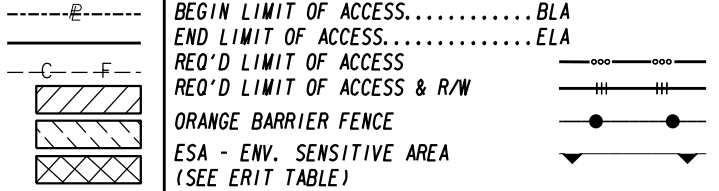

REVISION DATES	

BMP LOCATION DETAILS CREEK VIEW DRAINAGE IMPROVEMENTS		
CHECKED:	DATE:	DRAWING No.
BACKCHECKED:	DATE:	54-0001
CORRECTED:	DATE:	
VERIFIED:	DATE:	



EROSION CONTROL NOTES:
 INITIAL/CONSTRUCTION PHASE: INSTALL CHECK DAMS AND INLET SEDIMENT TRAPS AS REQUIRED.
 FINAL PHASE: PERMANENT GRASSING/SOD SHALL BE ESTABLISHED AFTER ALL CONSTRUCTION ACTIVITIES ARE COMPLETED. CHECK DAMS AND INLET SEDIMENT TRAPS SHALL BE REMOVED ONCE GRASSING IS ESTABLISHED.
 TOTAL DISTURBED AREA = 0.15 AC

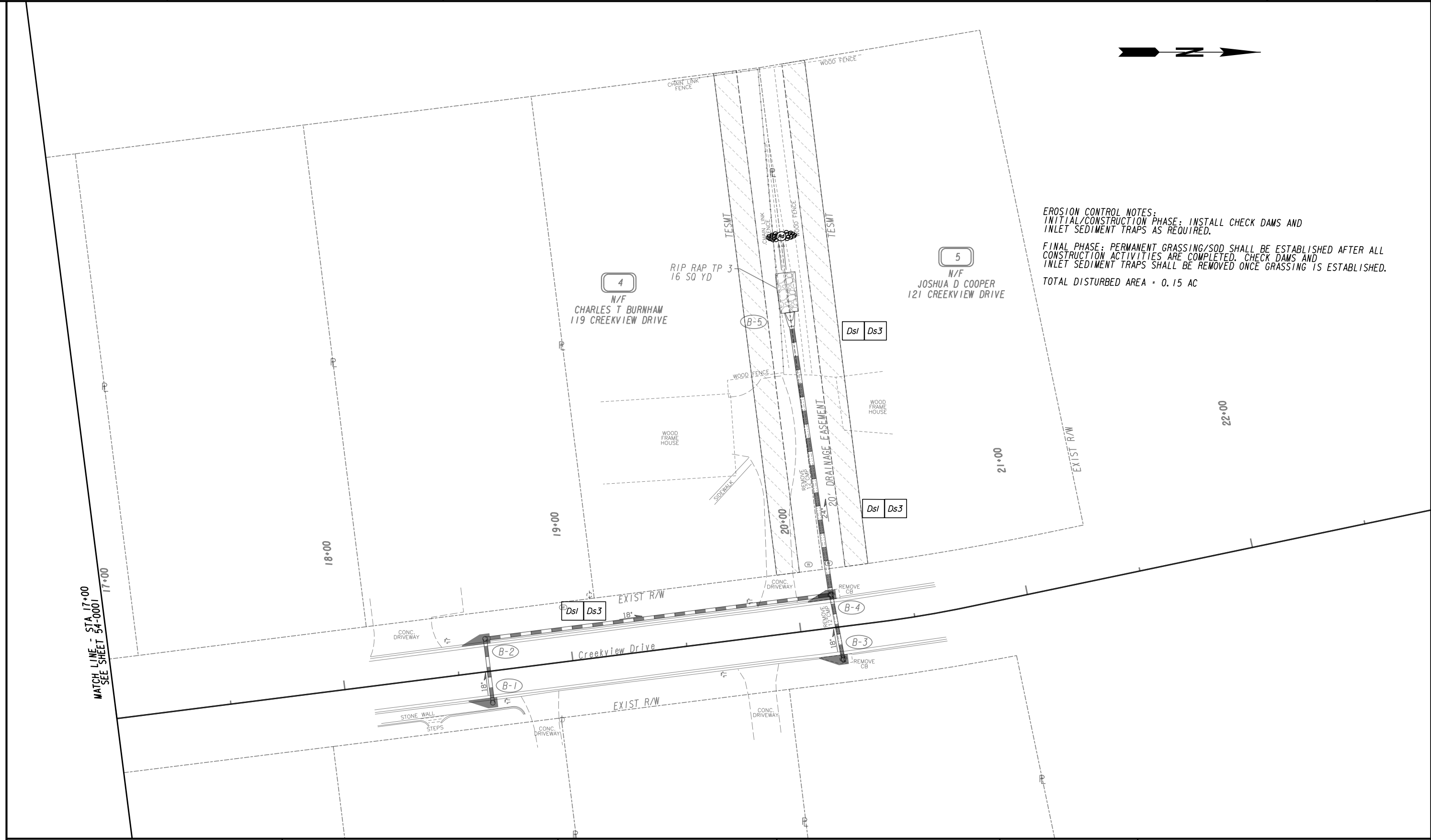

PROPERTY AND EXISTING R/W LINE
 REQUIRED R/W LINE
 CONSTRUCTION LIMITS
 EASEMENT FOR CONSTR
 & MAINTENANCE OF SLOPES
 EASEMENT FOR CONSTR OF SLOPES
 EASEMENT FOR CONSTR OF DRIVES

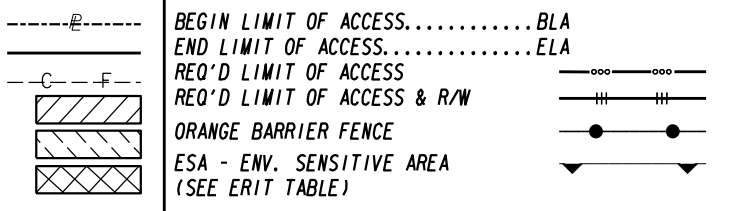

REVISION DATES	

BMP LOCATION DETAILS		
CREEK VIEW		
DRAINAGE IMPROVEMENTS		
CHECKED:	DATE:	DRAWING No.
BACKCHECKED:	DATE:	54-0002
CORRECTED:	DATE:	
VERIFIED:	DATE:	



EROSION CONTROL NOTES:
 INITIAL/CONSTRUCTION PHASE: INSTALL CHECK DAMS AND INLET SEDIMENT TRAPS AS REQUIRED.
 FINAL PHASE: PERMANENT GRASSING/SOD SHALL BE ESTABLISHED AFTER ALL CONSTRUCTION ACTIVITIES ARE COMPLETED. CHECK DAMS AND INLET SEDIMENT TRAPS SHALL BE REMOVED ONCE GRASSING IS ESTABLISHED.
 TOTAL DISTURBED AREA = 0.15 AC

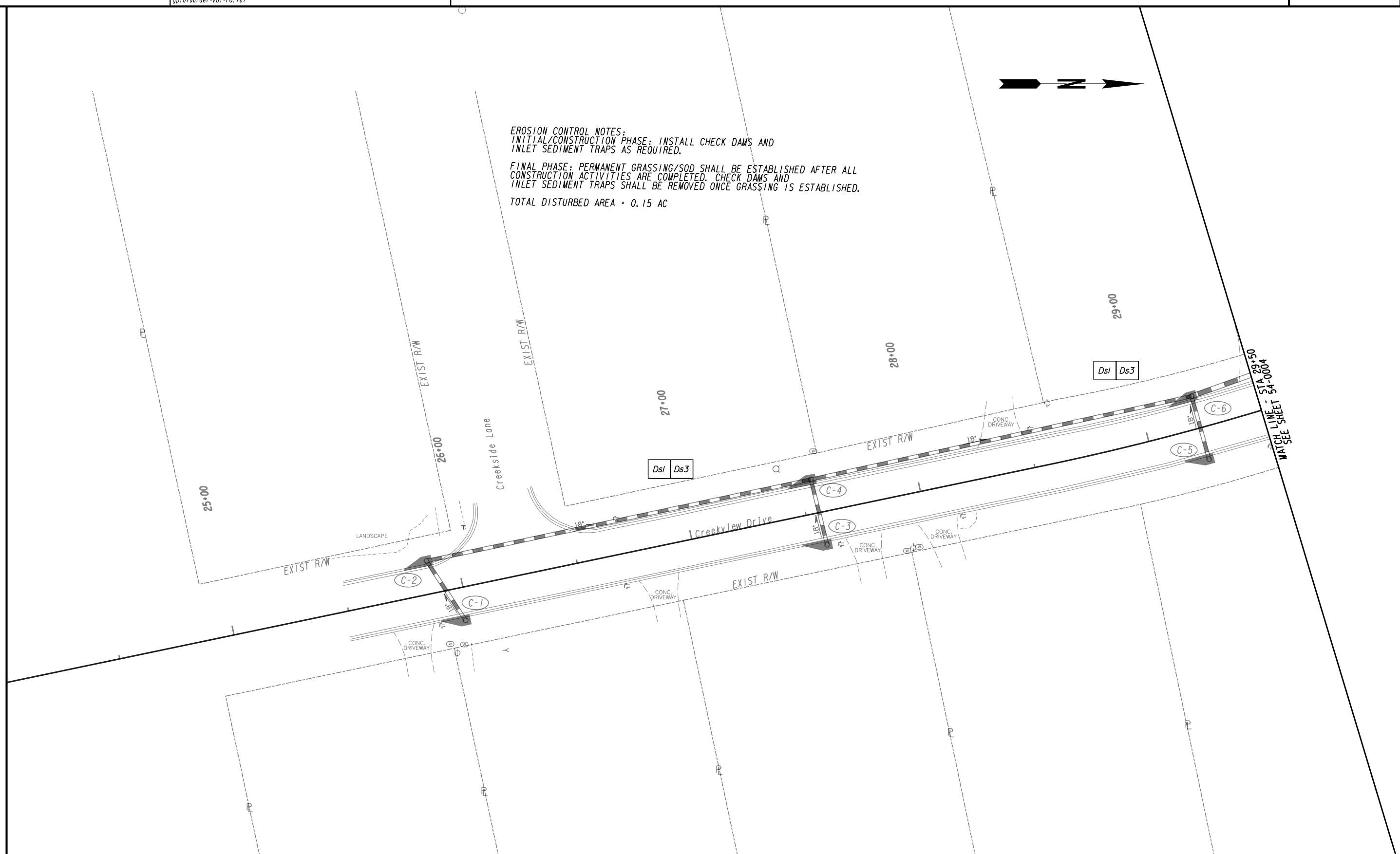

STA 29+50
 MATCH LINE - SHEET 54-0004
 MATCH SEE

PROPERTY AND EXISTING R/W LINE
 REQUIRED R/W LINE
 CONSTRUCTION LIMITS
 EASEMENT FOR CONSTR
 & MAINTENANCE OF SLOPES
 EASEMENT FOR CONSTR OF SLOPES
 EASEMENT FOR CONSTR OF DRIVES

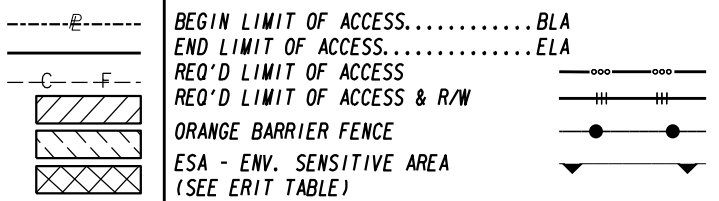

BEGIN LIMIT OF ACCESS.....BLA
 END LIMIT OF ACCESS.....ELA
 REQ'D LIMIT OF ACCESS
 REQ'D LIMIT OF ACCESS & R/W
 ORANGE BARRIER FENCE
 ESA - ENV. SENSITIVE AREA
 (SEE ERIT TABLE)

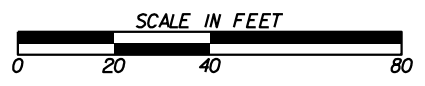

REVISION DATES	

BMP LOCATION DETAILS		
CREEK VIEW		
DRAINAGE IMPROVEMENTS		
CHECKED:	DATE:	DRAWING No.
BACKCHECKED:	DATE:	54-0003
CORRECTED:	DATE:	
VERIFIED:	DATE:	

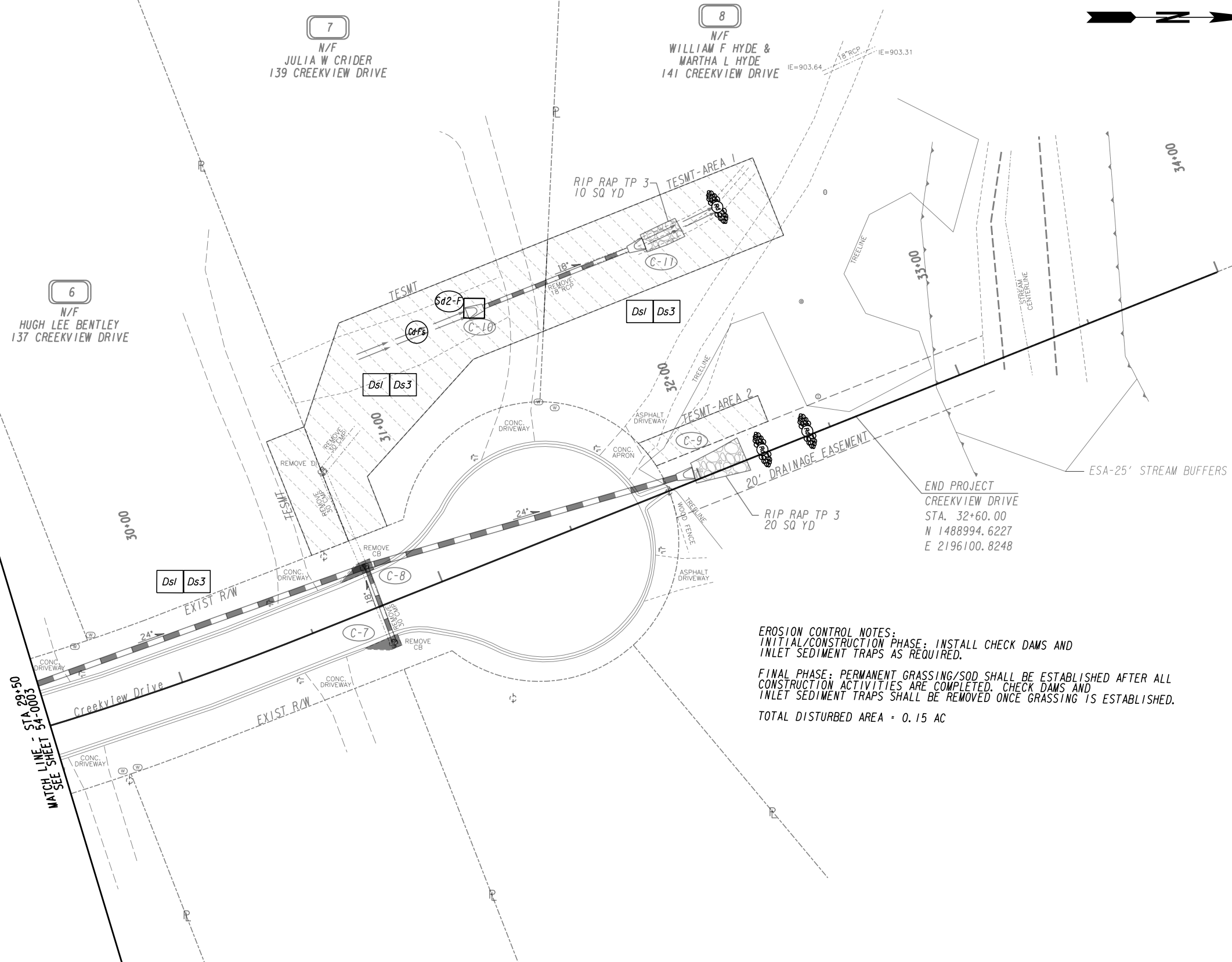

END PROJECT
CREEKVIEW DRIVE
STA. 32+60.00
N 1488994.6227
E 2196100.8248

EROSION CONTROL NOTES:
INITIAL/CONSTRUCTION PHASE: INSTALL CHECK DAMS AND INLET SEDIMENT TRAPS AS REQUIRED.
FINAL PHASE: PERMANENT GRASSING/SOD SHALL BE ESTABLISHED AFTER ALL CONSTRUCTION ACTIVITIES ARE COMPLETED. CHECK DAMS AND INLET SEDIMENT TRAPS SHALL BE REMOVED ONCE GRASSING IS ESTABLISHED.
TOTAL DISTURBED AREA = 0.15 AC

PROPERTY AND EXISTING R/W LINE
REQUIRED R/W LINE
CONSTRUCTION LIMITS
EASEMENT FOR CONSTR
& MAINTENANCE OF SLOPES
EASEMENT FOR CONSTR OF SLOPES
EASEMENT FOR CONSTR OF DRIVES

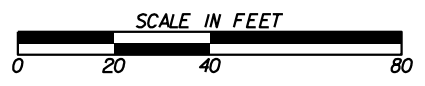
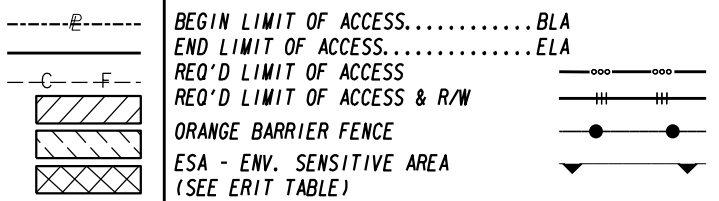

REVISION DATES	

BMP LOCATION DETAILS
CREEK VIEW
DRAINAGE IMPROVEMENTS

CHECKED:	DATE:	DRAWING No.
BACKCHECKED:	DATE:	54-0004
CORRECTED:	DATE:	
VERIFIED:	DATE:	

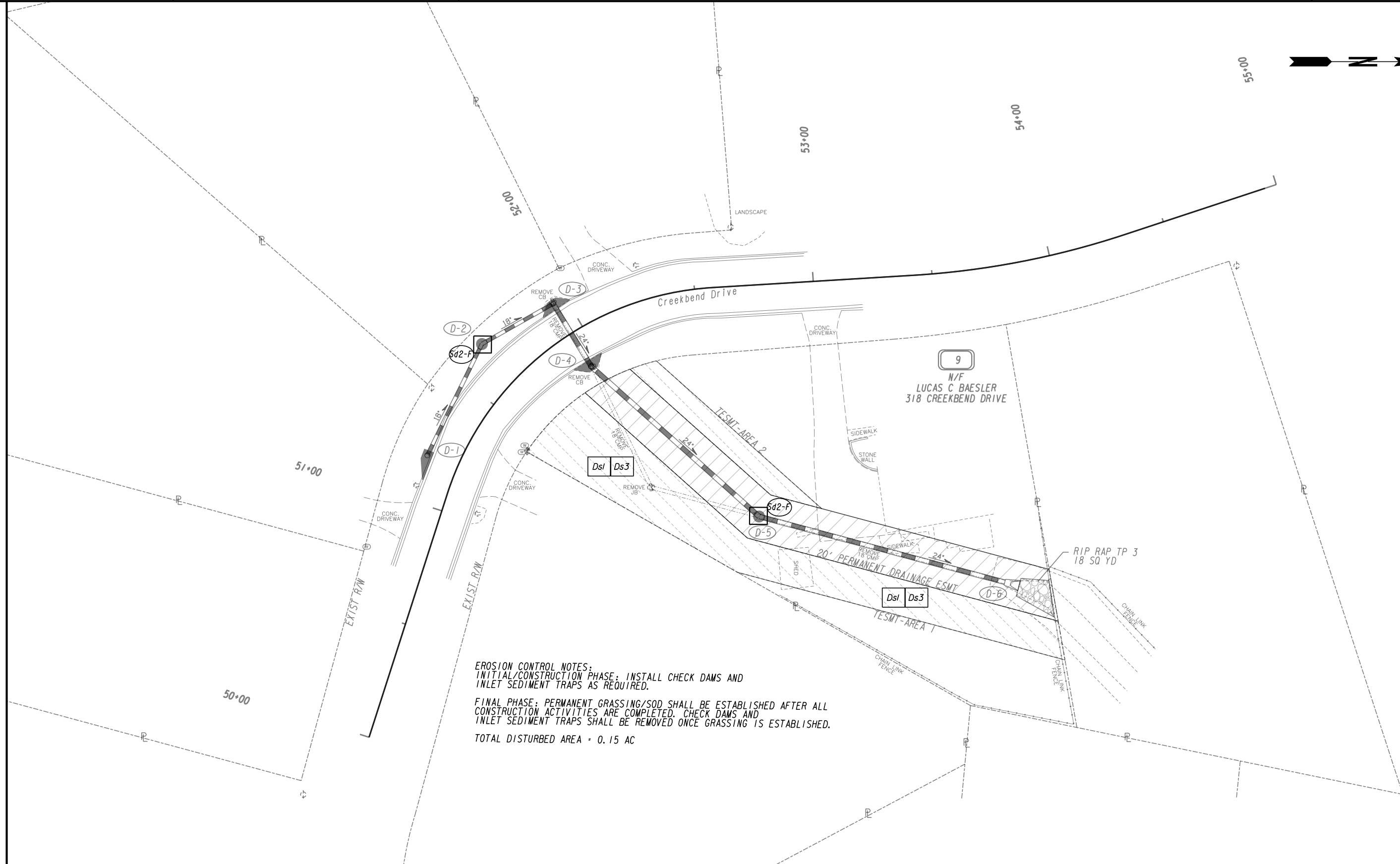

EROSION CONTROL NOTES:
 INITIAL/CONSTRUCTION PHASE: INSTALL CHECK DAMS AND INLET SEDIMENT TRAPS AS REQUIRED.
 FINAL PHASE: PERMANENT GRASSING/SOD SHALL BE ESTABLISHED AFTER ALL CONSTRUCTION ACTIVITIES ARE COMPLETED. CHECK DAMS AND INLET SEDIMENT TRAPS SHALL BE REMOVED ONCE GRASSING IS ESTABLISHED.
 TOTAL DISTURBED AREA = 0.15 AC

PROPERTY AND EXISTING R/W LINE
 REQUIRED R/W LINE
 CONSTRUCTION LIMITS
 EASEMENT FOR CONSTR
 & MAINTENANCE OF SLOPES
 EASEMENT FOR CONSTR OF SLOPES
 EASEMENT FOR CONSTR OF DRIVES

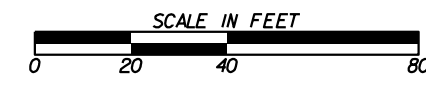
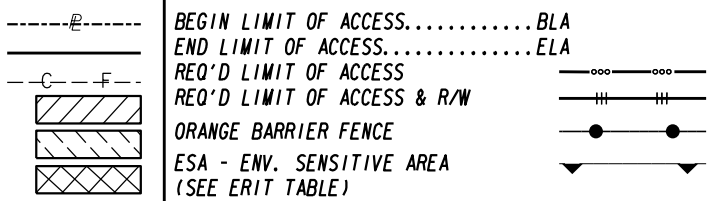

REVISION DATES	

BMP LOCATION DETAILS
 CREEK VIEW
 DRAINAGE IMPROVEMENTS

CHECKED:		DATE:		DRAWING No.
BACKCHECKED:		DATE:		54-0005
CORRECTED:		DATE:		
VERIFIED:		DATE:		

EROSION CONTROL NOTES:
 INITIAL/CONSTRUCTION PHASE: INSTALL CHECK DAMS AND INLET SEDIMENT TRAPS AS REQUIRED.
 FINAL PHASE: PERMANENT GRASSING/SOD SHALL BE ESTABLISHED AFTER ALL CONSTRUCTION ACTIVITIES ARE COMPLETED. CHECK DAMS AND INLET SEDIMENT TRAPS SHALL BE REMOVED ONCE GRASSING IS ESTABLISHED.
 TOTAL DISTURBED AREA = 0.15 AC



10
 N/F
 KELLY J KRUER
 431 CREEKSIDE LANE

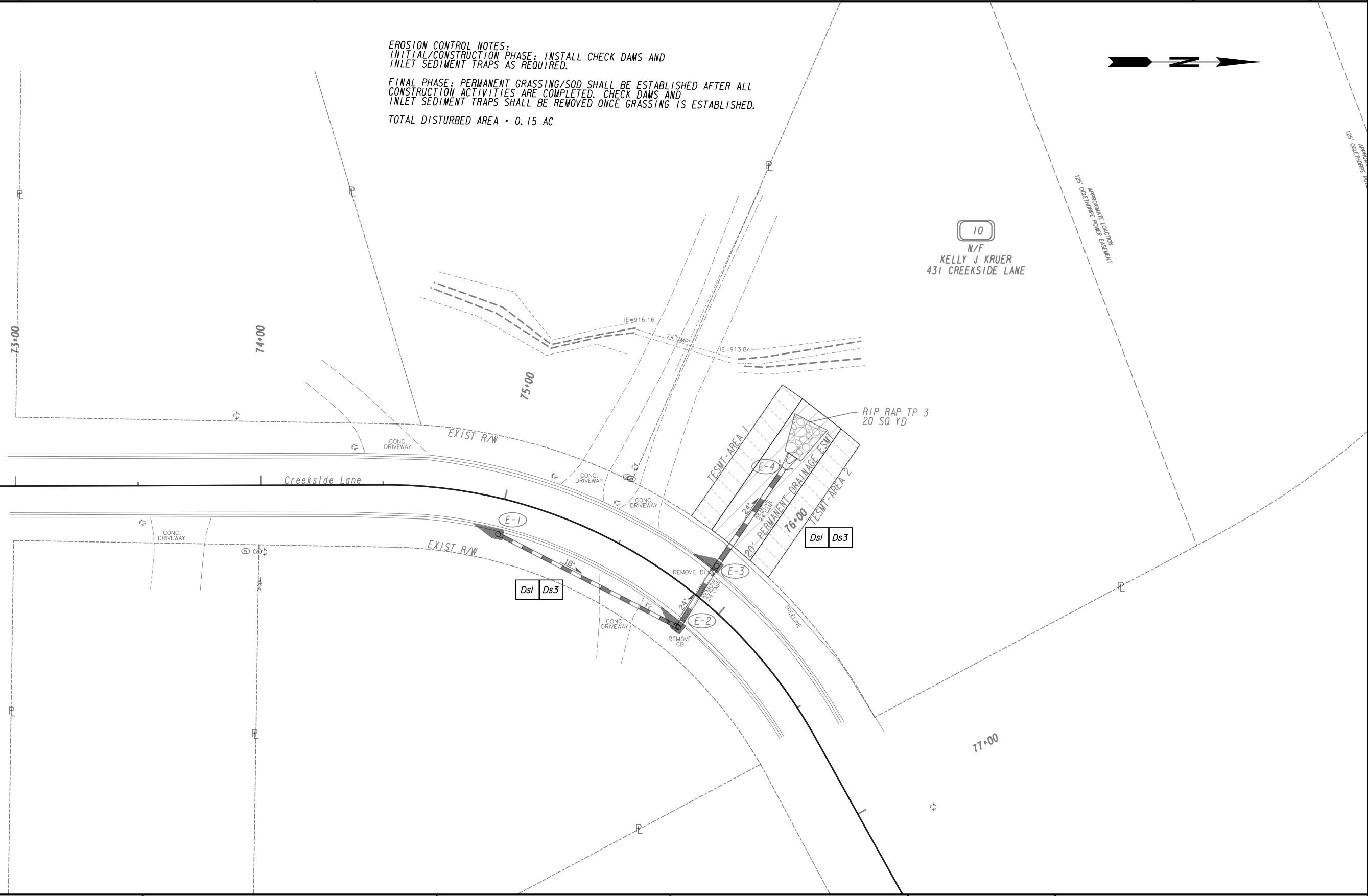

PROPERTY AND EXISTING R/W LINE
 REQUIRED R/W LINE
 CONSTRUCTION LIMITS
 EASEMENT FOR CONSTR
 & MAINTENANCE OF SLOPES
 EASEMENT FOR CONSTR OF SLOPES
 EASEMENT FOR CONSTR OF DRIVES

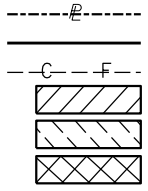

BEGIN LIMIT OF ACCESS.....BLA
 END LIMIT OF ACCESS.....ELA
 REQ'D LIMIT OF ACCESS
 REQ'D LIMIT OF ACCESS & R/W
 ORANGE BARRIER FENCE
 ESA - ENV. SENSITIVE AREA
 (SEE ERIT TABLE)

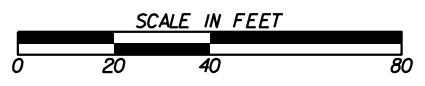

REVISION DATES	

BMP LOCATION DETAILS		
CREEK VIEW		
DRAINAGE IMPROVEMENTS		
CHECKED:	DATE:	DRAWING No.
BACKCHECKED:	DATE:	54-0006
CORRECTED:	DATE:	
VERIFIED:	DATE:	

CHEROKEE COUNTY SPLOST ROADWAY PROGRAM RIGHT OF WAY OF PROPOSED CREEK VIEW SUBDIVISION DRAINAGE IMPROVEMENTS PROJECT 74008

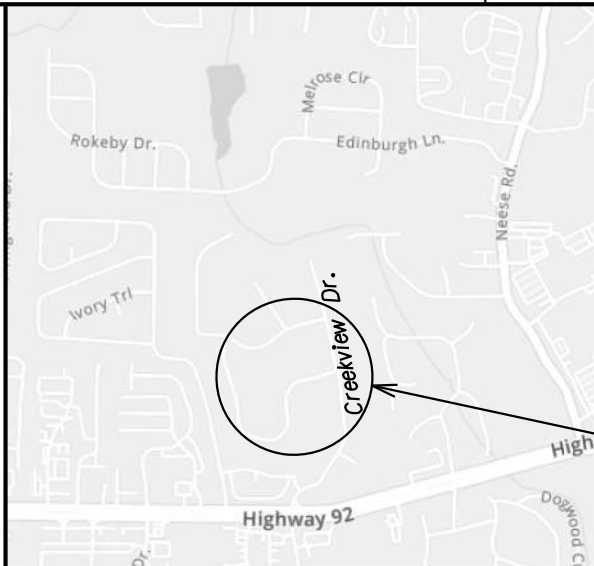
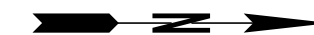

PROJECT
LOCATION

LOCATION SKETCH

THIS PROJECT HAS BEEN PREPARED USING THE HORIZONTAL GEORGIA COORDINATE SYSTEM OF 1984 (NAD 1983)/94 WEST ZONE, AND THE NORTH AMERICAN VERTICAL DATUM (NAVD) OF 1988.

BEGIN R/W ACQUISITION
CREEKVIEW DRIVE
STA. 11+89.79
N 1487028.7930
E 2196251.4987

END R/W ACQUISITION
CREEKVIEW DRIVE
STA. 32+60.00
N 1488994.6227
E 2196100.8248

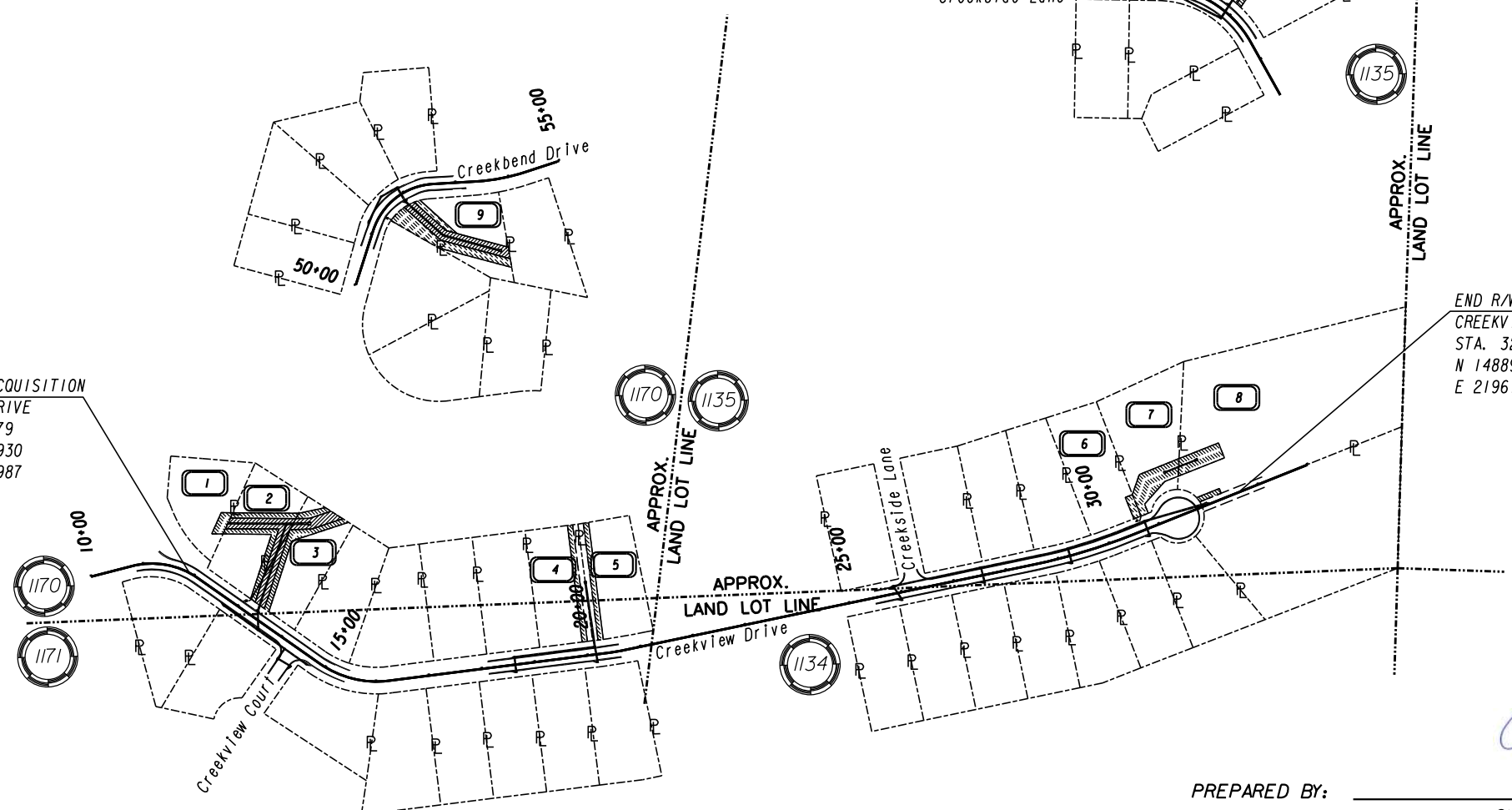

Charlie Lanz
REGISTERED PROFESSIONAL ENGINEER
CHARLIE A. LANZ

PREPARED BY: CHARLIE A. LANZ, PE

PLANS PREPARED BY:

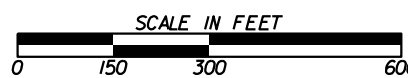

CONVENTIONAL SIGNS		
LAND LOT LINE	
PROPERTY LINE	
RIGHT OF WAY LINE	EXISTING
	REQUIRED
	EXISTING LIMIT OF ACCESS	---ooo---
	REQUIRED LIMIT OF ACCESS	ooo---
	EXISTING LIMIT OF ACCESS & R/W	---ooo---
REQUIRED LIMIT OF ACCESS & R/W	ooo---	
R/W MARKERS	⊠	
FENCE	---x---	

CHEROKEE COUNTY (057)

LAND LOT
1170, 1171, 1134, 1135

PLANS COMPLETED 01-24-2024	REVISIONS

DRAWING No.
60-0001

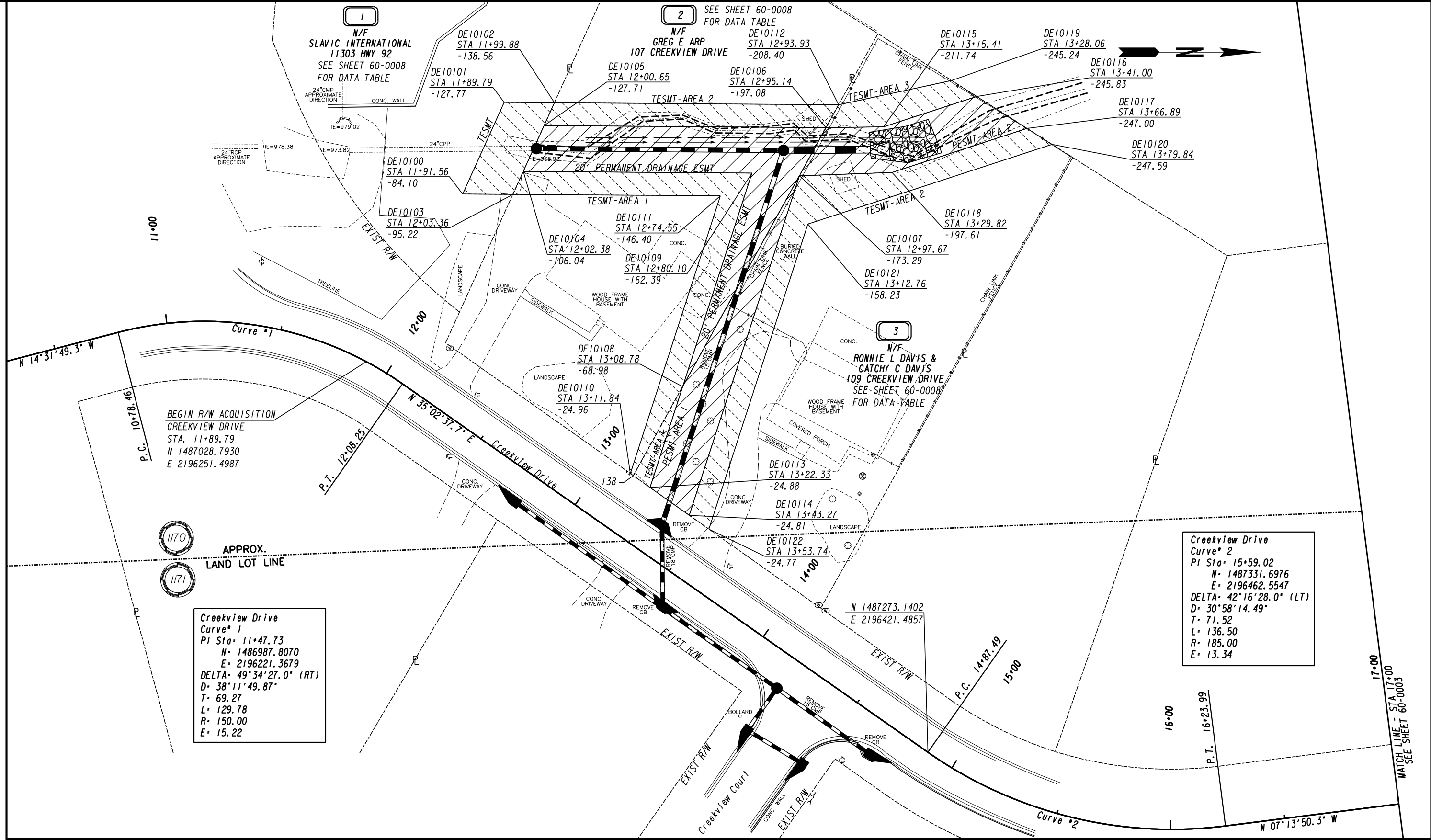

Creekview Drive Curve 1
 PI Sta: 11+47.73
 N: 1486987.8070
 E: 2196221.3679
 DELTA: 49°34'27.0" (RT)
 D: 38'11"49.87"
 T: 69.27
 L: 129.78
 R: 150.00
 E: 15.22

Creekview Drive Curve 2
 PI Sta: 15+59.02
 N: 1487331.6976
 E: 2196462.5547
 DELTA: 42°16'28.0" (LT)
 D: 30°58'14.49"
 T: 71.52
 L: 136.50
 R: 185.00
 E: 13.34

PROPERTY AND EXISTING R/W LINE
 REQUIRED R/W LINE
 CONSTRUCTION LIMITS
 EASEMENT FOR CONSTR
 & MAINTENANCE OF SLOPES
 EASEMENT FOR CONSTR OF SLOPES
 EASEMENT FOR CONSTR OF DRIVES

---e--- BEGIN LIMIT OF ACCESS.....BLA
 ---f--- END LIMIT OF ACCESS.....ELA
 ---c---f--- REQ'D LIMIT OF ACCESS
 ---h---h--- REQ'D LIMIT OF ACCESS & R/W
 [Hatched Box] ORANGE BARRIER FENCE
 [Dotted Box] ESA - ENV. SENSITIVE AREA
 (SEE ERIT TABLE)

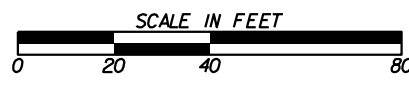

REVISION DATES	

RIGHT OF WAY PLAN CREEK VIEW DRAINAGE IMPROVEMENTS		
CHECKED:	DATE:	DRAWING No.
BACKCHECKED:	DATE:	60-0002
CORRECTED:	DATE:	
VERIFIED:	DATE:	

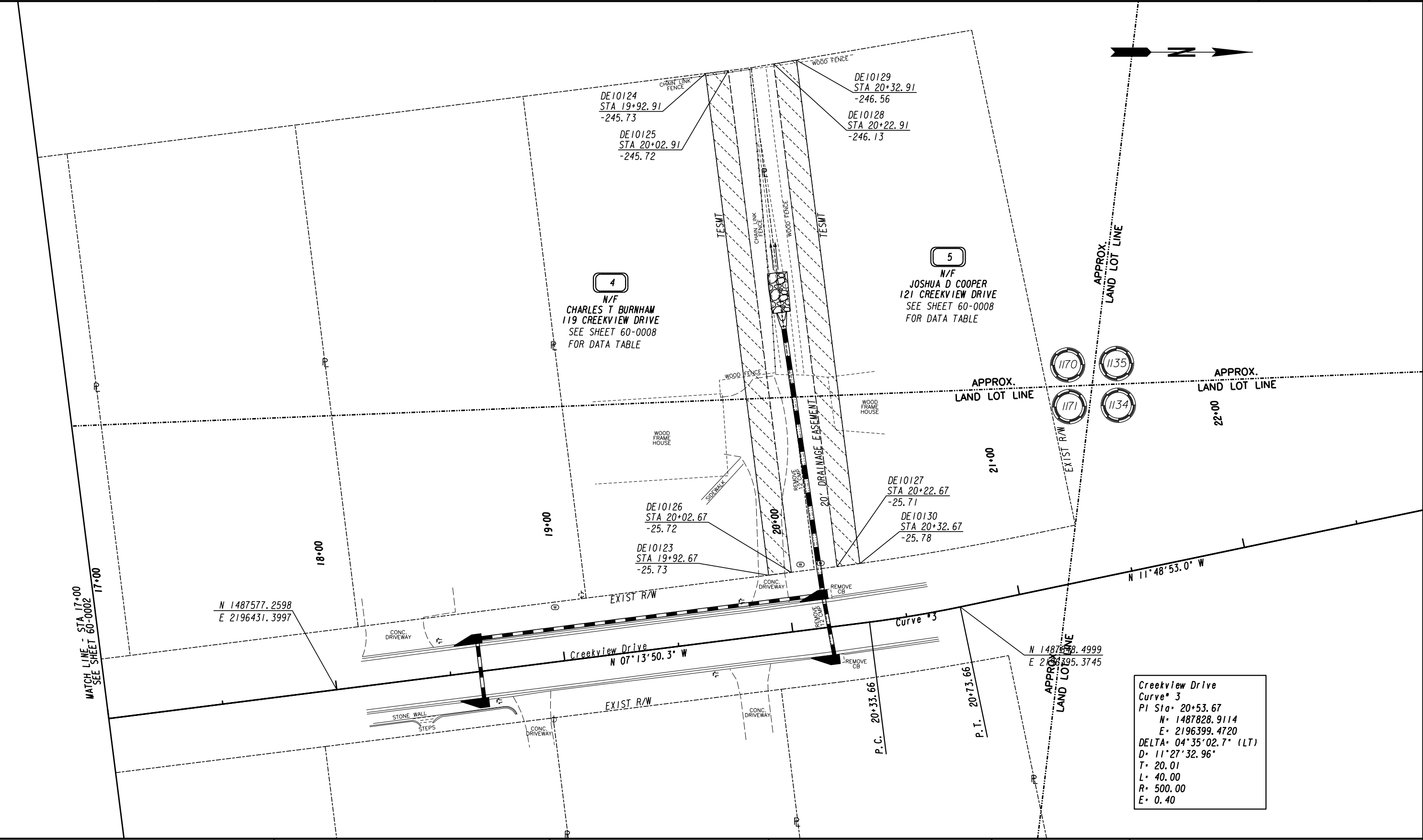

**Creekview Drive
 Curve # 3**
 PI Sta: 20+53.67
 N: 1487828.9114
 E: 2196399.4720
 DELTA: 04°35'02.7" (LT)
 D: 11°27'32.96"
 T: 20.01
 L: 40.00
 R: 500.00
 E: 0.40

PROPERTY AND EXISTING R/W LINE
 REQUIRED R/W LINE
 CONSTRUCTION LIMITS
 EASEMENT FOR CONSTR
 & MAINTENANCE OF SLOPES
 EASEMENT FOR CONSTR OF SLOPES
 EASEMENT FOR CONSTR OF DRIVES

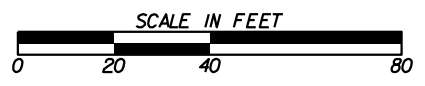
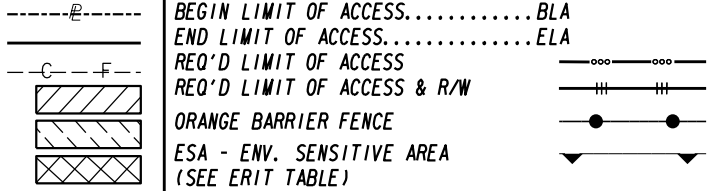

REVISION DATES	

RIGHT OF WAY PLAN CREEK VIEW DRAINAGE IMPROVEMENTS		
CHECKED:	DATE:	DRAWING No. 60-0003
BACKCHECKED:	DATE:	
CORRECTED:	DATE:	
VERIFIED:	DATE:	

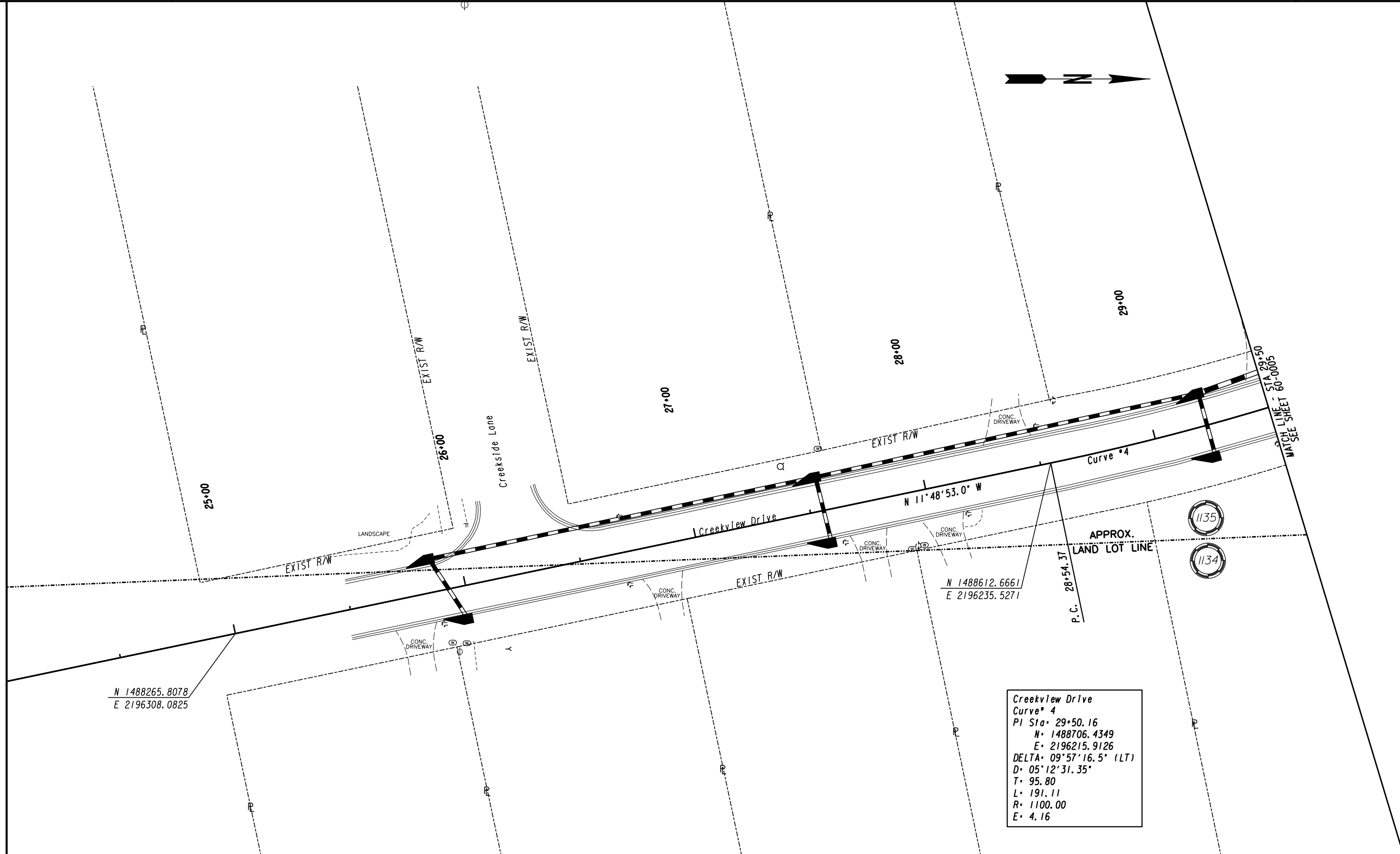

N 1488265.8078
E 2196308.0825

N 1488612.6661
E 2196235.5271

**Creekview Drive
Curve # 4**
 PI Sta: 29+50.16
 N: 1488706.4349
 E: 2196215.9126
 DELTA: 09°57'16.5" (LT)
 D: 05°12'31.35"
 T: 95.80
 L: 191.11
 R: 1100.00
 E: 4.16

PROPERTY AND EXISTING R/W LINE
 REQUIRED R/W LINE
 CONSTRUCTION LIMITS
 EASEMENT FOR CONSTR
 & MAINTENANCE OF SLOPES
 EASEMENT FOR CONSTR OF SLOPES
 EASEMENT FOR CONSTR OF DRIVES

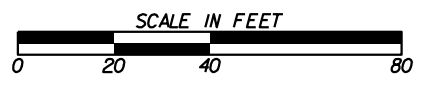
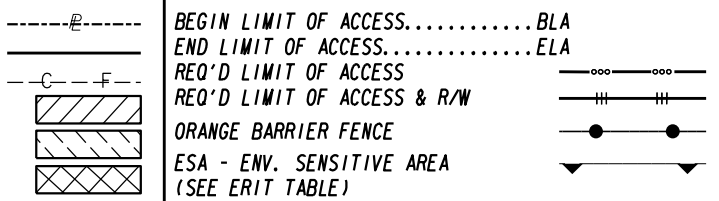

REVISION DATES	

RIGHT OF WAY PLAN
 CREEK VIEW
 DRAINAGE IMPROVEMENTS

CHECKED:	DATE:	DRAWING No. 60-0004
BACKCHECKED:	DATE:	
CORRECTED:	DATE:	
VERIFIED:	DATE:	

**Creekview Drive
Curve # 4**
 PI Sta= 29+50.16
 N= 1488706.4349
 E= 2196215.9126
 DELTA= 09°57'16.5" (LT)
 D= 05°12'31.35"
 T= 95.80
 L= 191.11
 R= 1100.00
 E= 4.16

7
 N/F
 JULIA W CRIDER
 139 CREEKVIEW DRIVE
 SEE SHEET 60-0008
 FOR DATA TABLE

8
 N/F
 WILLIAM F HYDE &
 MARTHA L HYDE
 141 CREEKVIEW DRIVE
 SEE SHEET 60-0008
 FOR DATA TABLE

6
 N/F
 HUGH LEE BENTLEY
 137 CREEKVIEW DRIVE
 SEE SHEET 60-0008
 FOR DATA TABLE

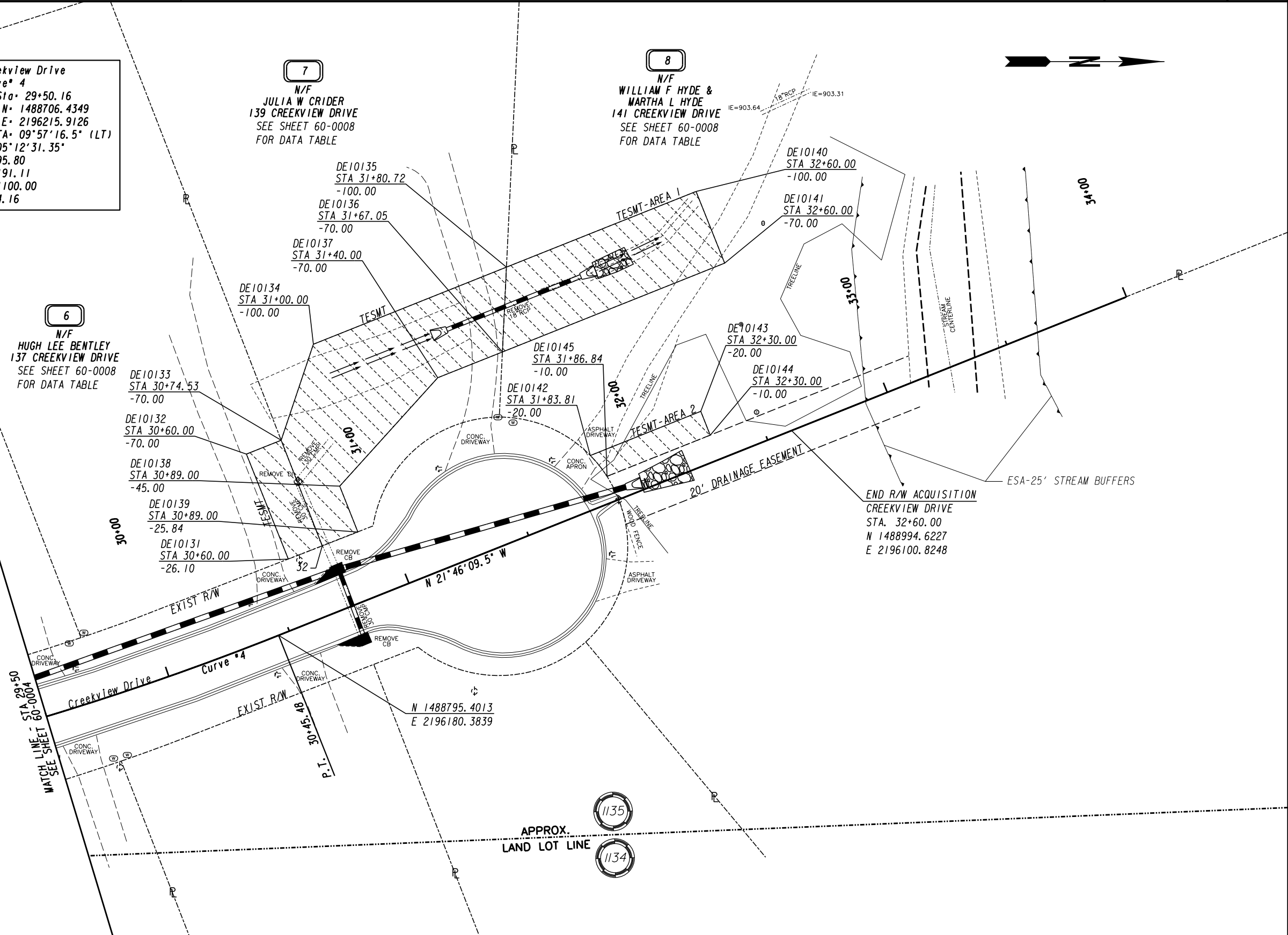

PROPERTY AND EXISTING R/W LINE
 REQUIRED R/W LINE
 CONSTRUCTION LIMITS
 EASEMENT FOR CONSTR
 & MAINTENANCE OF SLOPES
 EASEMENT FOR CONSTR OF SLOPES
 EASEMENT FOR CONSTR OF DRIVES

-----e-----
 ---C---F---
 [Hatched Box]
 [Hatched Box]
 [Hatched Box]

BEGIN LIMIT OF ACCESS.....BLA
 END LIMIT OF ACCESS.....ELA
 REQ'D LIMIT OF ACCESS
 REQ'D LIMIT OF ACCESS & R/W
 ORANGE BARRIER FENCE
 ESA - ENV. SENSITIVE AREA
 (SEE ERIT TABLE)

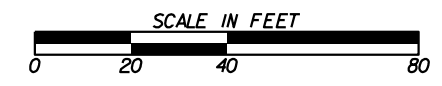

REVISION DATES	

RIGHT OF WAY PLAN CREEK VIEW DRAINAGE IMPROVEMENTS		
CHECKED:	DATE:	DRAWING No.
BACKCHECKED:	DATE:	60-0005
CORRECTED:	DATE:	
VERIFIED:	DATE:	

Creekbend Drive
Curve # 5
PI Sta: 51+93.11
N= 1487399.8483
E= 2195528.0624
DELTA= 68°40'19.5" (RT)
D= 45°50'11.84"
T= 85.38
L= 149.82
R= 125.00
E= 26.38

Creekbend Drive
Curve # 6
PI Sta: 53+87.46
N= 1487614.7466
E= 2195514.9014
DELTA= 14°43'54.8" (LT)
D= 16°22'12.80"
T= 45.25
L= 89.99
R= 350.00
E= 2.91

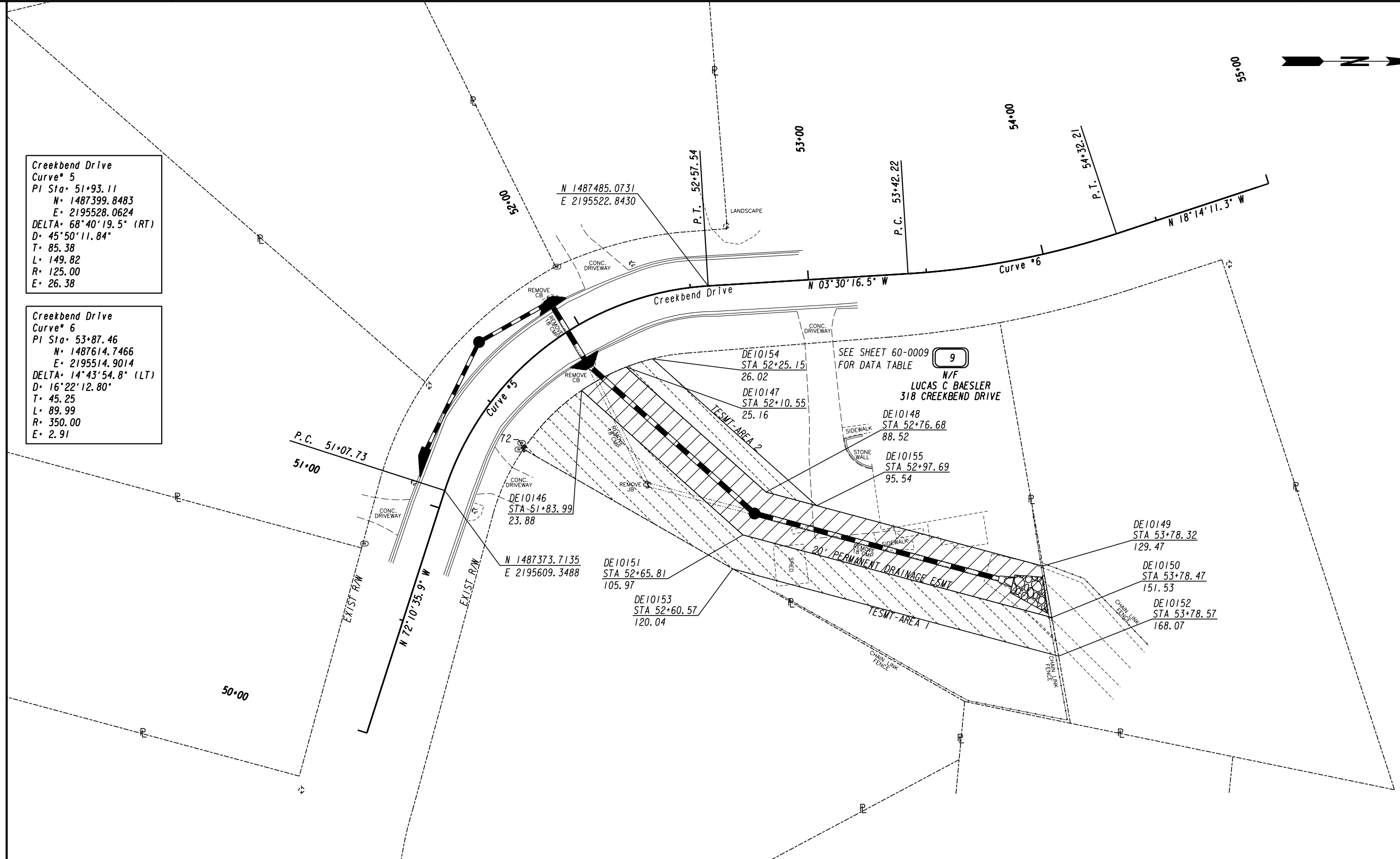

SEE SHEET 60-0009 FOR DATA TABLE

9

N/F
LUCAS C BAESLER
318 CREEKBEND DRIVE

DE10154
STA 52+25.15
26.02

DE10147
STA 52+10.55
25.16

DE10148
STA 52+76.68
88.52

DE10155
STA 52+97.69
95.54

DE10146
STA 51+83.99
23.88

DE10151
STA 52+65.81
105.97

DE10153
STA 52+60.57
120.04

DE10149
STA 53+78.32
129.47

DE10150
STA 53+78.47
151.53

DE10152
STA 53+78.57
168.07

PROPERTY AND EXISTING R/W LINE
REQUIRED R/W LINE
CONSTRUCTION LIMITS
EASEMENT FOR CONSTR
& MAINTENANCE OF SLOPES
EASEMENT FOR CONSTR OF SLOPES
EASEMENT FOR CONSTR OF DRIVES

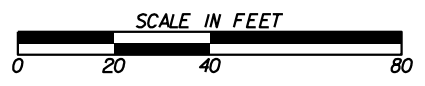
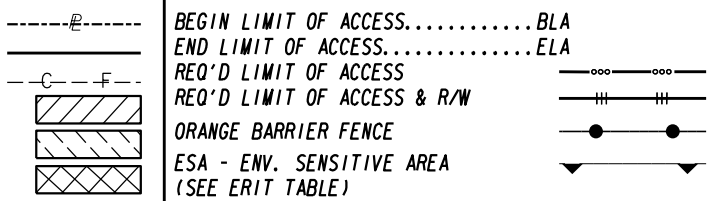

REVISION DATES	

RIGHT OF WAY PLAN
CREEK VIEW
DRAINAGE IMPROVEMENTS

CHECKED:	DATE:	DRAWING No.
BACKCHECKED:	DATE:	60-0006
CORRECTED:	DATE:	
VERIFIED:	DATE:	



10
N/F
KELLY J KRUER
431 CREEKSIDE LANE
SEE SHEET 60-0009
FOR DATA TABLE

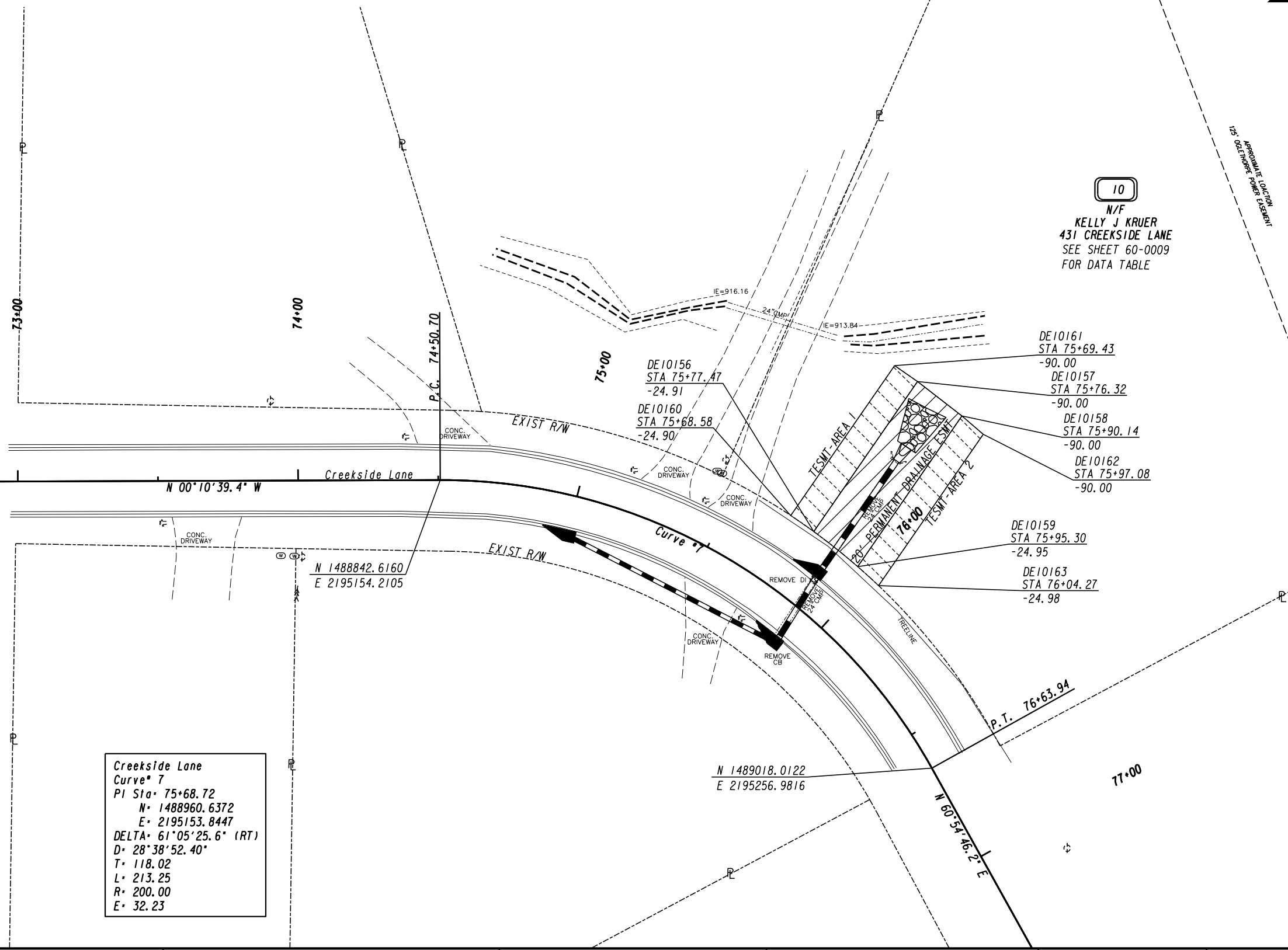

Creekside Lane
Curve 7
PI Sta 75+68.72
N 1488960.6372
E 2195153.8447
DELTA 61°05'25.6" (RT)
D 28°38'52.40"
T 118.02
L 213.25
R 200.00
E 32.23

PROPERTY AND EXISTING R/W LINE
REQUIRED R/W LINE
CONSTRUCTION LIMITS
EASEMENT FOR CONSTR
& MAINTENANCE OF SLOPES
EASEMENT FOR CONSTR OF SLOPES
EASEMENT FOR CONSTR OF DRIVES

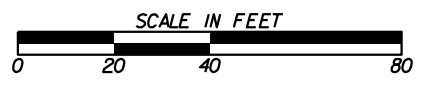
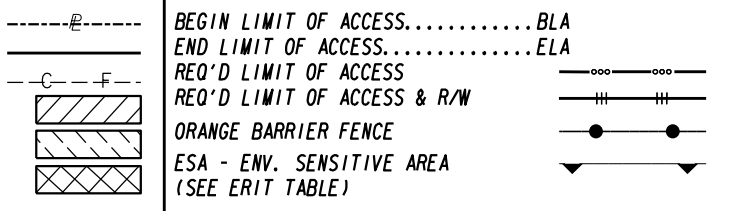

REVISION DATES	

RIGHT OF WAY PLAN CREEK VIEW DRAINAGE IMPROVEMENTS		
CHECKED:	DATE:	DRAWING No.
BACKCHECKED:	DATE:	60-0007
CORRECTED:	DATE:	
VERIFIED:	DATE:	

PAR 1 - TESMT REQ'D TEMP. EASM'T. DE101
PNT OFFSET/ STATION/ ALIGNMENT
DE10100 84.10 L 11+91.56 Creekview Drive C/L
DE10101 127.77 L 11+89.79 Creekview Drive C/L
DE10102 138.56 L 11+99.88 Creekview Drive C/L
DE10103 95.22 L 12+03.36 Creekview Drive C/L
DE10100 84.10 L 11+91.56 Creekview Drive C/L
REQD EASMT AREA = 875.50 SF

PAR 2 - PESMT REQ'D PERM. EASM'T. DE102
PNT OFFSET/ DIST STATION/ BEARING ALIGNMENT
DE10104 106.04 L 12+02.38 Creekview Drive C/L
DE10105 127.71 L 12+00.65 Creekview Drive C/L
DE10106 197.08 L 12+95.14 Creekview Drive C/L
DE10108 68.98 L 13+08.78 Creekview Drive C/L
DE10109 162.39 L 12+80.10 Creekview Drive C/L
DE10104 106.04 L 12+02.38 Creekview Drive C/L
REQD EASMT = 3421.85 SF
REQD EASMT = 0.079 ACRES

PAR 2 - TESMT - AREA 1 REQ'D TEMP. EASM'T. DE103
PNT OFFSET/ STATION/ ALIGNMENT
DE10103 95.22 L 12+03.36 Creekview Drive C/L
DE10104 106.04 L 12+02.38 Creekview Drive C/L
DE10109 162.39 L 12+80.10 Creekview Drive C/L
DE10108 68.98 L 13+08.78 Creekview Drive C/L
DE10110 24.96 L 13+11.84 Creekview Drive C/L
DE10111 146.40 L 12+74.55 Creekview Drive C/L
DE10103 95.22 L 12+03.36 Creekview Drive C/L
REQD EASMT AREA = 2108.53 SF

PAR 2 - TESMT - AREA 2 REQ'D TEMP. EASM'T. DE104
PNT OFFSET/ STATION/ ALIGNMENT
DE10105 127.71 L 12+00.65 Creekview Drive C/L
DE10102 138.56 L 11+99.88 Creekview Drive C/L
DE10112 208.40 L 12+93.93 Creekview Drive C/L
DE10106 197.08 L 12+95.14 Creekview Drive C/L
DE10105 127.71 L 12+00.65 Creekview Drive C/L
REQD EASMT AREA = 1231.89 SF

PAR 3 - PESMT - AREA 1 REQ'D PERM. EASM'T. DE105
PNT OFFSET/ DIST STATION/ BEARING ALIGNMENT
DE10113 24.88 L 13+22.33 Creekview Drive C/L
DE10108 68.98 L 13+08.78 Creekview Drive C/L
DE10107 173.29 L 12+97.67 Creekview Drive C/L
DE10114 24.81 L 13+43.27 Creekview Drive C/L
DE10113 24.88 L 13+22.33 Creekview Drive C/L
REQD EASMT = 2014.49 SF
REQD EASMT = 0.046 ACRES

PAR 3 - PESMT - AREA 2 REQ'D PERM. EASM'T. DE106
PNT OFFSET/ DIST STATION/ BEARING ALIGNMENT
DE10107 173.29 L 12+97.67 Creekview Drive C/L
DE10106 197.08 L 12+95.14 Creekview Drive C/L
DE10115 211.74 L 13+15.41 Creekview Drive C/L
DE10116 245.83 L 13+41.00 Creekview Drive C/L
DE10117 247.00 L 13+66.89 Creekview Drive C/L
DE10118 197.61 L 13+29.82 Creekview Drive C/L
DE10107 173.29 L 12+97.67 Creekview Drive C/L
REQD EASMT = 1705.73 SF
REQD EASMT = 0.039 ACRES

PAR 3 - TESMT - AREA 1 REQ'D TEMP. EASM'T. DE107
PNT OFFSET/ STATION/ ALIGNMENT
DE10108 68.98 L 13+08.78 Creekview Drive C/L
DE10113 24.88 L 13+22.33 Creekview Drive C/L
DE10113 24.96 L 13+13.47 Creekview Drive C/L
REQD EASMT AREA = 194.67 SF

PAR 3 - TESMT - AREA 2 REQ'D TEMP. EASM'T. DE108
PNT OFFSET/ STATION/ ALIGNMENT
DE10114 24.81 L 13+43.27 Creekview Drive C/L
DE10107 173.29 L 12+97.67 Creekview Drive C/L
DE10118 197.61 L 13+29.82 Creekview Drive C/L
DE10117 247.00 L 13+66.89 Creekview Drive C/L
DE10120 247.59 L 13+79.84 Creekview Drive C/L
DE10121 158.23 L 13+12.76 Creekview Drive C/L
DE10122 24.77 L 13+53.74 Creekview Drive C/L
DE10114 24.81 L 13+43.27 Creekview Drive C/L
REQD EASMT AREA = 2767.52 SF

PAR 3 - TESMT - AREA 3 REQ'D TEMP. EASM'T. DE109
PNT OFFSET/ STATION/ ALIGNMENT
DE10106 197.08 L 12+95.14 Creekview Drive C/L
DE10112 208.40 L 12+93.93 Creekview Drive C/L
DE10119 245.24 L 13+28.06 Creekview Drive C/L
DE10116 245.83 L 13+41.00 Creekview Drive C/L
DE10115 211.74 L 13+15.41 Creekview Drive C/L
DE10106 197.08 L 12+95.14 Creekview Drive C/L
REQD EASMT AREA = 675.40 SF

PAR 4 - TESMT REQ'D TEMP. EASM'T. DE110
PNT OFFSET/ STATION/ ALIGNMENT
DE10123 25.73 L 19+92.67 Creekview Drive C/L
DE10124 245.73 L 19+92.91 Creekview Drive C/L
DE10125 245.72 L 20+02.91 Creekview Drive C/L
DE10126 25.72 L 20+02.67 Creekview Drive C/L
DE10123 25.73 L 19+92.67 Creekview Drive C/L
REQD EASMT AREA = 2200.00 SF

PAR 5 - TESMT REQ'D TEMP. EASM'T. DE111
PNT OFFSET/ STATION/ ALIGNMENT
DE10127 25.71 L 20+22.67 Creekview Drive C/L
DE10128 246.13 L 20+22.91 Creekview Drive C/L
DE10129 246.56 L 20+32.91 Creekview Drive C/L
DE10130 25.78 L 20+32.67 Creekview Drive C/L
ARC LENGTH = 10.00
CHORD BEAR = S 7°38'02.7" E
LNTH CHORD = 10.00
RADIUS = 1202.30
DEGREE = 4°45'55.9"
DE10127 25.71 L 20+22.67 Creekview Drive C/L
REQD EASMT AREA = 2206.12 SF

PAR 6 - TESMT REQ'D TEMP. EASM'T. DE112
PNT OFFSET/ STATION/ ALIGNMENT
DE10131 26.10 L 30+60.00 Creekview Drive C/L
DE10132 70.00 L 30+60.00 Creekview Drive C/L
DE10133 70.00 L 30+74.53 Creekview Drive C/L
DE10131 26.10 L 30+60.00 Creekview Drive C/L
DE10131 26.10 L 30+60.00 Creekview Drive C/L
REQD EASMT AREA = 630.10 SF

PAR 7 - TESMT REQ'D TEMP. EASM'T. DE113
PNT OFFSET/ STATION/ ALIGNMENT
DE10133 70.00 L 30+74.53 Creekview Drive C/L
DE10134 100.00 L 31+00.00 Creekview Drive C/L
DE10135 100.00 L 31+80.72 Creekview Drive C/L
DE10136 70.00 L 31+67.05 Creekview Drive C/L
DE10137 70.00 L 31+40.00 Creekview Drive C/L
DE10138 45.00 L 30+89.00 Creekview Drive C/L
DE10139 25.84 L 30+89.00 Creekview Drive C/L
DE10139 25.97 L 30+74.13 Creekview Drive C/L
REQD EASMT AREA = 3883.00 SF

PAR 8 - TESMT - AREA 1 REQ'D TEMP. EASM'T. DE114
PNT OFFSET/ STATION/ ALIGNMENT
DE10136 70.00 L 31+67.05 Creekview Drive C/L
DE10135 100.00 L 31+80.72 Creekview Drive C/L
DE10140 100.00 L 32+60.00 Creekview Drive C/L
DE10141 70.00 L 32+60.00 Creekview Drive C/L
DE10136 70.00 L 31+67.05 Creekview Drive C/L
REQD EASMT AREA = 2583.36 SF

PAR 8 - TESMT - AREA 2 REQ'D TEMP. EASM'T. DE115
PNT OFFSET/ STATION/ ALIGNMENT
DE10142 20.00 L 31+83.81 Creekview Drive C/L
DE10143 20.00 L 32+30.00 Creekview Drive C/L
DE10144 10.00 L 32+30.00 Creekview Drive C/L
DE10145 10.00 L 31+86.84 Creekview Drive C/L
ARC LENGTH = 10.47
CHORD BEAR = S 51°22'24.4" W
LNTH CHORD = 10.45
RADIUS = 50.00
DEGREE = 114°35'29.6"
DE10142 20.00 L 31+83.81 Creekview Drive C/L
REQD EASMT AREA = 444.85 SF

REVISION DATES
RIGHT OF WAY PLAN
CREEK VIEW DRAINAGE IMPROVEMENTS
CHECKED: DATE:
BACKCHECKED: DATE:
CORRECTED: DATE:
DRAWING No. 60-0008
VERIFIED: DATE:



 PAR 9 - PESMT REQ'D PERM. EASM'T. DE116

PNT	OFFSET/ DIST	STATION/ BEARING	ALIGNMENT
DE10146	23.88 R	51+83.99	Creekbend Drive C/L
ARC LENGTH = 21.40			
CHORD BEAR = N 27°43'05.2" W			
LNTH CHORD = 21.35			
RADIUS = 92.00			
DEGREE = 62°16'40.9"			
DE10147	25.16 R	52+10.55	Creekbend Drive C/L
N 41°48'04.6" E			
DE10148	88.52 R	52+76.68	Creekbend Drive C/L
N 14°58'35.4" E			
DE10149	129.47 R	53+78.32	Creekbend Drive C/L
N 80°01'40.8" E			
DE10150	151.53 R	53+78.47	Creekbend Drive C/L
S 14°58'35.4" W			
DE10151	105.97 R	52+65.81	Creekbend Drive C/L
S 41°48'04.6" W			
DE10146	23.88 R	51+83.99	Creekbend Drive C/L
REQD EASMT = 4281.58 SF			
REQD EASMT = 0.098 ACRES			

 PAR 9 - TESMT - AREA 1 REQ'D TEMP. EASM'T. DE117

PNT	OFFSET/ DIST	STATION/ BEARING	ALIGNMENT
72	22.78 R	51+40.92	Creekbend Drive C/L
ARC LENGTH = 35.09			
CHORD BEAR = N 45°18'29.8" W			
LNTH CHORD = 34.88			
RADIUS = 92.00			
DEGREE = 62°16'40.9"			
DE10146	23.88 R	51+83.99	Creekbend Drive C/L
DE10151	105.97 R	52+65.81	Creekbend Drive C/L
DE10150	151.53 R	53+78.47	Creekbend Drive C/L
DE10152	168.07 R	53+78.57	Creekbend Drive C/L
DE10153	120.04 R	52+60.57	Creekbend Drive C/L
72	22.78 R	51+40.92	Creekbend Drive C/L
REQD EASMT AREA = 4463.66 SF			

 PAR 9 - TESMT - AREA 2 REQ'D TEMP. EASM'T. DE118

PNT	OFFSET/ DIST	STATION/ BEARING	ALIGNMENT
DE10147	25.16 R	52+10.55	Creekbend Drive C/L
ARC LENGTH = 11.65			
CHORD BEAR = N 17°25'42.9" W			
LNTH CHORD = 11.64			
RADIUS = 92.00			
DEGREE = 62°16'40.9"			
DE10154	26.02 R	52+25.15	Creekbend Drive C/L
DE10155	95.54 R	52+97.69	Creekbend Drive C/L
DE10148	88.52 R	52+76.68	Creekbend Drive C/L
DE10147	25.16 R	52+10.55	Creekbend Drive C/L
REQD EASMT AREA = 863.76 SF			

 PAR 10 - PESMT REQ'D PERM. EASM'T. DE119

PNT	OFFSET/ DIST	STATION/ BEARING	ALIGNMENT
DE10156	24.91 L	75+77.47	Creekside Lane C/L
N 55°19'28.1" W			
DE10157	90.00 L	75+76.32	Creekside Lane C/L
N 37°47'28.5" E			
DE10158	90.00 L	75+90.14	Creekside Lane C/L
S 55°19'28.1" E			
DE10159	24.95 L	75+95.30	Creekside Lane C/L
ARC LENGTH = 20.05			
CHORD BEAR = S 38°35'11.7" W			
LNTH CHORD = 20.05			
RADIUS = 226.04			
DEGREE = 25°20'51.5"			
DE10156	24.91 L	75+77.47	Creekside Lane C/L
REQD EASMT = 1301.85 SF			
REQD EASMT = 0.030 ACRES			

 PAR 10 - TESMT - AREA 1 REQ'D TEMP. EASM'T. DE120

PNT	OFFSET/ DIST	STATION/ BEARING	ALIGNMENT
DE10160	24.90 L	75+68.58	Creekside Lane C/L
DE10161	90.00 L	75+69.43	Creekside Lane C/L
DE10157	90.00 L	75+76.32	Creekside Lane C/L
DE10156	24.91 L	75+77.47	Creekside Lane C/L
ARC LENGTH = 10.00			
CHORD BEAR = S 34°46'39.3" W			
LNTH CHORD = 10.00			
RADIUS = 226.04			
DEGREE = 25°20'51.5"			
DE10160	24.90 L	75+68.58	Creekside Lane C/L
REQD EASMT AREA = 650.69 SF			

 PAR 10 - TESMT - AREA 2 REQ'D TEMP. EASM'T. DE121

PNT	OFFSET/ DIST	STATION/ BEARING	ALIGNMENT
DE10159	24.95 L	75+95.30	Creekside Lane C/L
DE10158	90.00 L	75+90.14	Creekside Lane C/L
DE10162	90.00 L	75+97.08	Creekside Lane C/L
DE10163	24.98 L	76+04.27	Creekside Lane C/L
ARC LENGTH = 10.09			
CHORD BEAR = S 42°24'25.9" W			
LNTH CHORD = 10.09			
RADIUS = 226.04			
DEGREE = 25°20'51.5"			
DE10159	24.95 L	75+95.30	Creekside Lane C/L
REQD EASMT AREA = 654.88 SF			



REVISION DATES

RIGHT OF WAY PLAN
CREEK VIEW
DRAINAGE IMPROVEMENTS

CHECKED:	DATE:	DRAWING No.
BACKCHECKED:	DATE:	60-0009
CORRECTED:	DATE:	
VERIFIED:	DATE:	